

KWAME NKRUMAH UNIVERSITY OF SCIENCE AND TECHNOLOGY, KUMASI

COLLEGE OF ARCHITECTURE AND PLANNING

DEPARTMENT OF BUILDING TECHNOLOGY

KNUST

**EXPLORING THE LEVEL OF KNOWLEDGE AND USAGE OF THE SEVEN
BASIC QUALITY CONTROL TOOLS BY PRODUCERS OF
PRECAST CONCRETE PRODUCTS IN GHANA**

By

Isaac Aidoo (BSc. Hons.) Building Technology

**A Thesis submitted to the Department of Building Technology,
Kwame Nkrumah University of Science and Technology in partial fulfilment of the
requirements for the degree of
MASTER OF PHILOSOPHY
CONSTRUCTION MANAGEMENT**

November, 2014

DECLARATION

This work or any part thereof has not previously been submitted in any form to the University or to any other body whether for the purpose of assessment, publication or for any other purpose. Put aside any expression, acknowledgements, reference and/or bibliographies cited in the work, I confirm that the intellectual content of this work is the result of my own efforts and no other person.

ISAAC AIDOO

(PG7140712)

Signature..... Date.....

Certify by:

SUPERVISOR: DR. EMMANUEL ADINYIRA

Signature..... Date.....

HEAD OF DEPARTMENT: PROFESSOR JOSHUA AYARKWA

Signature..... Date

ABSTRACT

For very small companies, the root cause of quality problems may be obvious but once we get beyond the very small business, most decision points and problem's root cause or the best-course decision will remain obscure until valid data are studied and analyzed. It is for these cases that quality management tools play an important role to improve the quality standards of the projects that the company undertakes. This research seek to explore the level of knowledge and the level of usage of the seven basic quality control tools by producers of precast concrete products and identify practical measures to improve quality control in the production of Precast concrete products in Ghana. The data was analyzed using gap and quadrant analysis and presented using tables and graphs. The findings indicated that the level of knowledge and usage of the seven basic quality control tools by these manufacturers is limited even though their perception about quality (Quality control) is very much on point. Again, the survey identified thirteen practical measures to improve and implement quality control namely, Process improvement guidelines and strategies, Incentives for good performance, Regular inspections and audits, Regular meetings between key stake holders i.e. design team, production team and users, Well defined roles and responsibilities, Customer involvement, Communication between management and production unit, Clearly defined goals and objectives, Training and Education of work force, a clear policy on quality control, Employee involvement- Frontline workers involvement in decision making on product quality, Skilled workforce (Production), Management commitment to quality. These measures are to be given attention for smooth improvement and ensure the successful implementation of total quality management in this industry. A proposed framework of quality control improvement and implementation has been derived from literature and the empirical study reported in this work. This frame work will contribute a lot to the Ghanaian construction industry and encourage producers of precast

concrete products to adopt the seven basic quality control tools to ensure quality of their products

Keywords: Knowledge, usage, quality control, tools, precast concrete product, Ghana

KNUST



ACKNOWLEDGEMENT

First of all, I readily acknowledge and give thanks to Mighty God, the Omnipotent and Omniscient who created everything and gave me the ability to begin and complete this project.

I owe lots of gratitude to my Supervisors, Professor Joshua Ayarkwa and Dr.

Emmanuel Adinyira, for the invaluable guidance, advices, motivations, critics and friendship.

Without their help, this thesis would not have been the same as presented here. I am also grateful to Eric and Elorm, for their guidance in using the software, SPSS, for analyzing my data.

I also wish to express my special thanks and appreciation to Auntie Connie and Auntie Francesca of the Building Department Office for their support and encouragement.

My sincere appreciation is also extended to my lovely wife, Flora Aidoo and my two wonderful kids, Kweku and Effe. Many thanks to my entire course mates for their support throughout the course.

All examiners deserve sincere commendation for their input in making the entire exercise a success and to all those, too numerous to name, who were not specifically mentioned, I say thank you.

Finally, I wish to thank my mother, my brothers and sisters for their encouragement and support throughout the course. This course is a dream come through.

God bless you all.

DEDICATION

To my loving family for their unflinching support and encouragement throughout my academic life

KNUST



TABLE OF CONTENT

DECLARATION.....	i
ABSTRACT.....	ii
ACKNOWLEDGEMENT.....	iv
DEDICATION.....	v
TABLE OF CONTENT.....	vi
LIST OF TABLES.....	xiii
LIST OF FIGURES.....	xiv

CHAPTER ONE	1
1 INTRODUCTION.....	1
1.1 BACKGROUND.....	1
1.2 PROBLEM STATEMENT.....	3
1.3 AIM OF THE RESEARCH	4
1.4 OBJECTIVES OF THE RESEARCH.....	4
1.5 RESEARCH QUESTIONS	4
1.6 BRIEF RESEARCH METHODOLOGY	5
1.6.1 Sources of Data	5
1.6.2 Sample Size	5

1.6.3 Data Analysis and Presentation of Results	6
1.7 SCOPE OF THE STUDY	6
1.8 SIGNIFICANT OF THE STUDY	6
1.9 ORGANISATION OF THE THESIS	8
8 CHAPTER TWO	9
LITERATURE REVIEW	9
2.1 AN OVERVIEW OF THE GHANAIAN CONSTRUCTION INDUSTRY	9
2.1.1 Construction Sector's Contribution to Gross Domestic Product	10
2.2 CONCEPT OF CONCRETE PRODUCTION	11
2.2.1 Historical Overview	11
2.2.2 Definition of concrete	12
2.2.3 Aggregates	12
2.2.4 Water	13
2.2.5 Cement	13
2.2.6. Curing	14
2.2.7 Site Testing of Materials	15
2.2.8 Concrete Mixes	16
2.2.9 Reinforced Concrete	17
2.2.10 Advantages and Disadvantages of Reinforced Concrete	19
2.2.11 Types of concretes	19
2.3 Introduction to Precast Concrete	20
2.3.1 History of Precast Concrete	21

2.3.2 The Many Uses of Precast Concrete	22
2.3.3 Merits of Precast	25
2.4 CONCEPT OF QUALITY CONTROL AND QUALITY MANAGEMENT	26
2.4.1 History and Evolution of Total Quality Management (TQM)	26
2.4.2 Operator Quality Control	28
2.4.3 Inspection Quality Control	28
2.4.4 Statistical Quality Control.....	29
2.4.5 Total Quality Control	30
2.5 THE MEANING OF QUALITY	32
2.5.1 Manufacturing-Based Definitions of Quality	34
2.5.2 User-Based Definitions of Quality.....	35
2.5.3 Comprehensive Approach for a Definition of Quality	36
2.5.4 Quality Dimensions	37
2.6 TOTAL QUALITY MANAGEMENT PRINCIPLES	39
2.7 TQM SYSTEM APPROACH.....	45
2.7.1 Definition of Total Quality Management (TQM)	45
2.7.2 Strategic Quality Management	46
2.7.3 Quality Planning	47
2.7.4 Quality Control	49
2.7.5 Quality Improvement	50
2.7.6 Quality Standards	52
2.7.7 ISO 9000	53

2.8 QUALITY CONTROL AND QUALITY ASSURANCE	
54	
2.8.1 Quality Control System Objective	55
2.8.2 Quality Control System Organization	56
2.8.3 Aspects to be controlled	57
2.8.4 Process Control	60
2.8.5 Defining a Process	61
2.8.6 Process Context	62
2.8.7 Quality Process Requirements	63
2.8.8 Quality Process Control	64
2.9 TOOLS AND TECHNIQUES FOR QUALITY CONTROL	
67	
2.9.1 The seven basic quality control tools	68
2.9.2 Check sheet	70
2.9.3 Control Chart	71
2.9.4 Histogram	72
2.9.5 Cause and effect diagram	73
2.10.6 Pareto chart	74
2.9.7 A scatter diagram	75
2.9.8 Flowchart	76
2.10 APPLICATION OF QUALITY TOOLS TO IMPROVE QUALITY	78
2.11 ADVANTAGES IN THE APPLICATION OF QUALITY CONTROL TOOLS	79
2.12 QUALITY CONTROL (QC) IN PRECAST CONCRETE PRODUCTION	
80	

2.13 CONCLUSION
81

CHAPTER THREE

83 RESEARCH METHODOLOGY
..... 83

3.1 INTRODUCTION
83

3.2 RESEARCH STRATEGY, DESIGN AND PROCESS
83

3.3 POPULATION AND SAMPLING
84

3.3.1 The research population and sample 84

3.3.2 Sampling Technique 85

3.4 DATA COLLECTION AND INSTRUMENTATION
85

3.4.1 Data Sources 85

3.4.2 Questionnaire Design
86

3.4.3 Content of the Questionnaire 86

3.4.4 Instrumentation and Response Rate 87

3.5 DATA PREPARATION AND ANALYSIS
88

CHAPTER FOUR

90 RESULTS AND DISCUSSION
..... 90

4.1 INTRODUCTION.....
90

4.2 PROFILES OF RESPONDENTS / COMPANY -DEMOGRAPHICS	91
4.3 LEVEL OF KNOWLEDGE ABOUT THE SEVEN BASIC QUALITY CONTROL TOOLS	97
4.4 LEVEL OF USAGE OF THE SEVEN BASIC QUALITY CONTROL TOOLS	98
4.5 GAP ANALYSIS OF LEVEL KNOWLEDGE AND LEVEL OF USAGE OF THE SEVEN BASIC QUALITY CONTROL TOOLS	99
4.6 PRACTICAL MEASURES TO IMPROVE QUALITY CONTROL	101
4.7 QUADRANT ANALYSIS OF THE LEVEL OF KNOWLEDGE AND THE LEVEL OF USAGE OF THE SEVEN BASIC QUALITY CONTROL TOOLS	103
CHAPTER FIVE	105
PROPOSED FRAMEWORK FOR QUALITY CONTROL	105
5.1 INTRODUCTION.....	105
5.2 THE NEED FOR A FRAMEWORK	105
5.3 FRAMEWORK DESIGN REQUIREMENTS	106
5.4 FOUR STAGES OF IMPROVEMENT AND IMPLEMENTATION	107
CHAPTER SIX	111
CONCLUSION AND RECOMMENDATIONS	111
6.1 INTRODUCTION.....	111

6.2 SUMMARY OF FINDINGS	112
6.3 COMMENTS ON OBJECTIVES ONE	112
6.4 COMMENT ON OBJECTIVES TWO	112
6.5 COMMENT ON THE THIRD OBJECTIVES	113
6.6 COMMENT ON THE FOURTH OBJECTIVES	114
6.7 CONCLUSION	115
6.8 RECOMMENDATIONS	116
6.9 FUTURE RESEARCH	117
6.10 LIMITATION OF THE STUDY	118
6.11 CONTRIBUTION TO KNOWLEDGE	118
REFERENCES	120
APPENDIX A	126
QUESTIONNAIRE.....	126

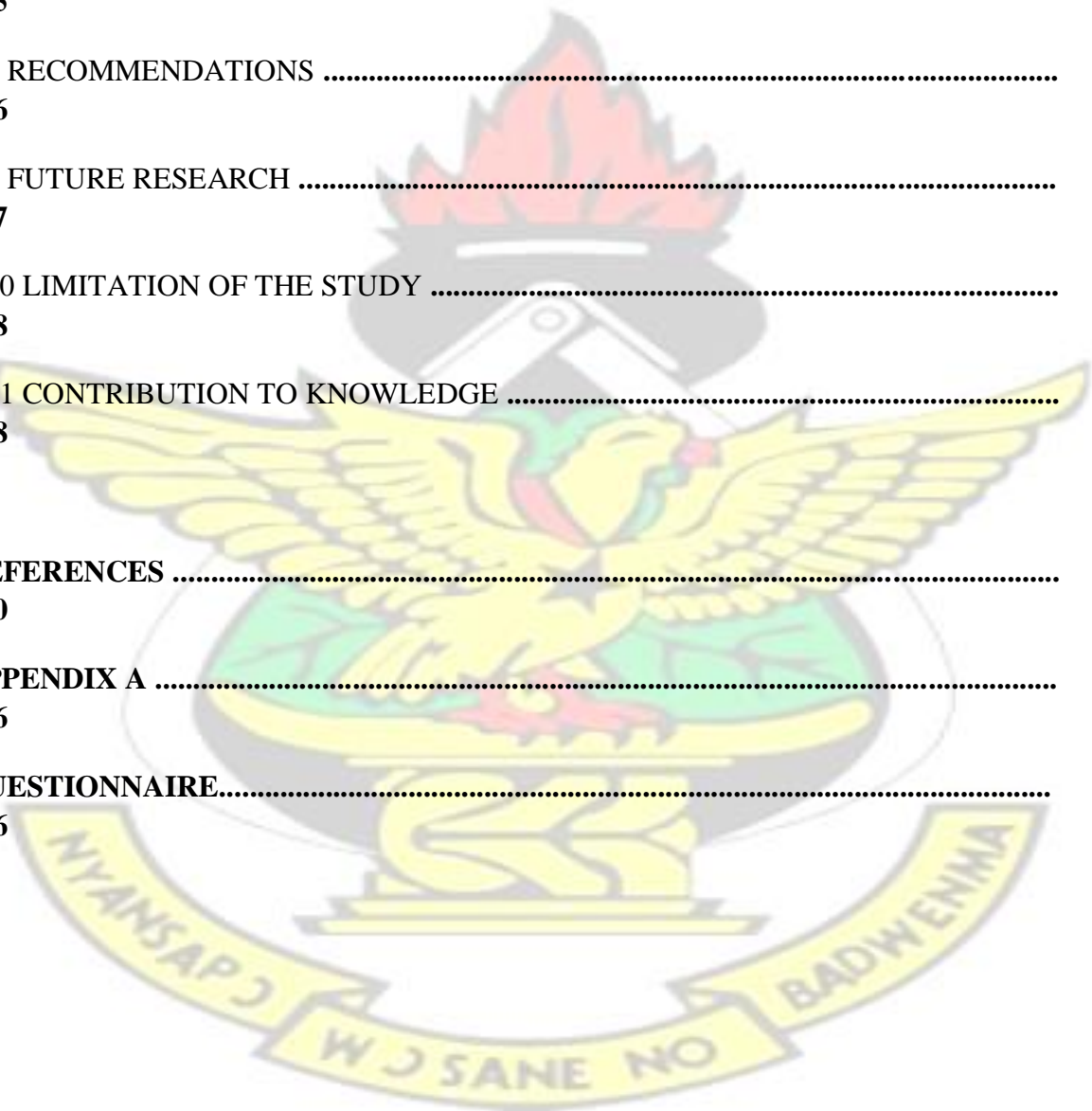

LIST OF TABLES

Table 4.1 Level of Knowledge about the seven basic quality control tools..... 100

Table 4.2 Level of usage of the seven basic quality control tools..... 101

Table 4.3 level of knowledge and level of usage gap analysis..... 102

Table 4.4 Suggested practical measures to improve quality control..... 104

Tab 4.5 Knowledge – Usage Quadrant Analysis..... 106

KNUST



LIST OF FIGURES

Figure 2.1 Relative share of the construction sector in gross Domestic Product.....	10
Fig. 2.2: Evolution and Development of Quality Control	27
Fig.2.3: Road-Map for Generalized Quality Planning Process.....	47
Fig. 2.4: PDCA Control Cycle	48
Fig. 2.5: Kaizen and Kairyo Improvements	50
Figure 2.6 Company-wide Quality Control.....	53
Figure 2.7 Aspect to be controlled.....	56
Fig. 2.8 Repeated Application of the PDCA Control Cycle.....	58
Fig. 2.9 Process Context	61
Fig. 2.10.: Feedback Loop.....	68
Fig 2.11. A typical Check Sheet for various steel tests.....	69
Fig. 2.12 A Typical Control hart.....	70
Fig 2.13 Atypical histogram.....	72
Fig. 2.14 Cause and Effect Diagram for analysis.....	73
Fig.2.15 The Pareto diagram.....	74
Fig. 2.16 Scatter Diagram.....	75
Fig.2.17 A typical flow chart of cement sampling and quality control.....	76
Fig. 4.1 level of Education.....	93
Fig.4.2 Job position.....	94
Fig. 4.3 Years of experience.....	94
Fig.4.4 Year of existence of company.....	95
Fig.4.5 Annual Turnover.....	96
Fig.4.6 Quality Department/ Unit.....	97
Fig. 4.7 Staff strength of QCD.....	97
Fig.4.8 Budget for QCD.....	98
Fig. 4.9 Knowledge about the seven basic quality control tools.....	98
Fig 5.1 Framework to improve Quality Control.....	110

KNUST



CHAPTER ONE

INTRODUCTION

1.1 BACKGROUND

Quality has been considered one of the most important and competitive factors amongst construction companies during the last two decades (Al-Ani & Al-Adhmawi, 2011). This has been likened to human civilization, and with the progress in human civilization, quality control will play an incomparable role in businesses (Ying, 2010). Even though quality can be defined in different ways by different writers, it is simply defined as the ability of the features of a project to meet the requirements needed by the final user (Ayandibu, 2010). Thorpe and Summer (1990) argued that quality is defined in different ways depending on the context in which it is needed and is defined by some writers as „the best or value for money“, whilst others refer to it as „the fitness for a purpose“.

All the activities that determine the quality policy, objectives, responsibilities and implementation by means such as quality planning, quality control, quality assurance and quality improvement within the quality system are referred to as quality management and must be an integral part of an organization’s overall management approach (Zairi, 1991; Ayandibu, 2010).

Exploring the quality control practices of manufacturing companies in simple terms refer to the investigation into the practices of manufacturing companies that leads to achieving the required products needed by the final user and also gives value for the money invested into the project.

This is very important since it helps such companies to survive in the industry. Ghana like many other developing countries is in her construction phase which requires an increase and improvement in infrastructure as a means to generating economic growth. The World Bank (2004), strategies to reduce poverty in developing countries focuses on two pillars of poverty reduction: empowering people by creating jobs through increased and improvement of infrastructure and improving the investment climate. However, the World Bank (2004) further emphasizes that major investments are not generating the quality or quantity of the services demanded.

With an increasing effort to meet the over 1.8 million housing deficit in Ghana, coupled with road construction, social amenities among other constructions, there is the need to ensure that good quality control measures are in place in order to prevent possible occurrence of accidents and product failures.

Literature has it that the construction industry has been criticized over the past two decades for its poor performance and productivity in relation to other industries, and management practices to support construction organizations are being challenged (Forbes, 1993; Alarcon & Ashley, 1992). (Frank & Roland, 2001) argued that the construction industry is based on craftsmanship; hence quality control and assurance procedures applied in manufacturing industry cannot be readily applied in construction where there are higher degrees of uniqueness in each and every project. In an attempt to bridge the gap between construction and manufacturing industry, the study of total quality management becomes imperative.

According to Ozaki (2003), construction clients and customers demand for enhanced product quality and lower production cost while Aoieong et al, (2002) are of the opinion that from a lean production perspective, defects and rework which are consequences of poor quality are

waste. The cost of poor quality has proved to be greater than the investment for managing quality and should therefore be eliminated (Zairi, 2000; Tukel and Rom, 2001; Bryde, 2003).

This has caused the industry to turn to the manufacturing sector as a point of reference and source of innovation by adopting successful concepts such as Total Quality Management (TQM), Lean (or Just-in-Time) Production and Reengineering among others derived from the manufacturing sector (Hoonakher *et al.*, 2010). These concepts are expected to solve the quality problems faced by the construction industry and to continually meet the needs of its customers (Jido, 1996; Fung & Wong, 1998).

1.2 PROBLEM STATEMENT

Embracing quality concept into concrete production is still struggling and described as an emerging concept in many developing countries. Adopting a contingency viewpoint, it can be mentioned that though, concrete product producers are fully aware of their obligations to the quality standards they operate in; they do not fully subscribe to it. Despite, the increasing importance of quality control in the production industry, very little or no studies have been conducted in Ghana to examine the subject in the context of precast concrete products. Again, relatively limited research has been devoted to exploring the level of knowledge and usage of the seven basic quality control tools that influence the success of quality management in developing countries and how Total Quality Management can be successfully improved and implemented in such countries. This study seeks to fill this research gap by exploring the level of knowledge and usage of the seven basic quality control tools and to identify practical measures to improve quality control in the manufacturing of precast concrete products in Ghana.

1.3 AIM OF THE RESEARCH

This research is carried out to explore the level of knowledge and the level of usage of the seven basic quality control tools by producers of precast concrete products in Ghana.

1.4 OBJECTIVES OF THE RESEARCH

In order to achieve the aim of the research some objectives have been formulated and these are outlined below:

1. To assess the level of knowledge of producers of precast concrete products in Ghana on the seven basic quality control tools.
2. To assess the level of usage of the seven basic quality control tools by producers of precast concrete products in Ghana.
3. To identify practical measures to improve quality control in the production of Precast concrete products in Ghana.
4. To propose a framework to improve quality in production of precast concrete products in Ghana.

1.5 RESEARCH QUESTIONS

To achieve the above objectives, the research seeks to answer the following questions;

1. What is the level of Knowledge of producers of precast concrete products in Ghana about the seven basic tools of quality?
2. What is the level of usage of the seven basic quality control tools in the production of precast concrete product in Ghana?
3. Which area of improvement in quality control is required by producers of precast concrete products?

1.6 BRIEF RESEARCH METHODOLOGY

The research method adopted for this study was largely quantitative in nature with data collection based on structured and semi-structured questionnaire administered to Production managers, Quality Control Managers, Project managers, Managing Directors, Operation Managers, Commercial Managers, Site Engineers, Factory Managers, Quantity Surveyors, Site Engineers and Planning Managers. In the preliminary process, an extensive literature review on the subject matter of the study was undertaken.

1.6.1 Sources of Data

Data was gathered from both primary and secondary sources. The primary sources comprised of data from questionnaires and interviews administered to the producers of concrete products companies that were selected. Documents from the construction companies and other relevant reports of related institutions were also considered. Secondary data was made up of relevant literature about concrete production and the seven basic quality control tools and total quality management practices in the industry in Ghana. Other sources include the internet, journals, published or unpublished materials.

1.6.2 Sample Size

The merits of sampling cannot be over emphasized as it saves money, labour and time, however, the sample selected should be an ideal representative of the entire population. Before selecting a sample, one must ensure he/she has the accurate sample frame. There should be a complete listing or compilation of all sampling units to form an accurate sample frame from which the sample size is then selected. In Ghana there are a number of concrete producers of precast concrete product companies offering services to different categories of clients. For the purpose of this research, 50 of these companies were contacted as the target group for the population.

1.6.3 Data Analysis and Presentation of Results

Responses (variables) were analysed using the SPSS software to perform basic descriptive statistics, gap and quadrant analyses and presented using tables, bar graphs and pie charts.

1.7 SCOPE OF THE STUDY

The research emphasised on the activities of producers of precast concrete products who are actively in operations in Accra and Tema and who have registered premises. The reason for using this category was because it is assumed that they are well organised and have a Quality control management department. Snowball sampling method was used for selecting the producers of precast concrete products to explore the level of knowledge and the level of usage of the seven basic quality control tools in their operations.

1.8 SIGNIFICANT OF THE STUDY

In view of the research problem stated in section 1.2, there is the need to encourage the practice of Quality management in concrete products industries in Ghana. This can reduce cost of rework, save time and increase efficiency as well as production. The idea of prefabrication of building elements in factory conditions brings with it certain inherent advantages over purely site-based construction (Taylor, 1999). Precast concrete manufacturing has an intrinsic environmental advantage compared with constructing similar products at a job site. Although it may be something we take for granted, this advantage has always been an important component of any precast product, and in today's environmentally conscious world it is becoming a more important value-added component of precast concrete products.

Precast elements have many natural advantages over pouring concrete at a job site. The environmental conditions in a precast concrete facility are much more consistent and can be managed much better than at a construction site, resulting in better quality. This prevents waste

from products that are rejected because of inconsistency. It also allows better control and monitoring of raw materials than when pouring at a construction site. Pouring on site also creates unexpected delays that result in wasted concrete when the ready-mix delivery has not been properly sequenced. These issues can be more easily managed at a precast facility, resulting in product that is made in a more environmentally friendly manner.

One of the key perceptions attributed to production in controlled environments such as precast concrete factories is that the greater degree of control (and the lesser degree of risk) will result in a higher quality product compared to its on-site equivalent. The ability to work in a weather-independent and controllable environment means that strength, surface quality and consistency, and detailed design features in precast concrete components should be much easier to achieve. Indeed both the material and dimensional properties of the product should benefit from such a production environment.

Fast construction on site means the project reaches hand-over more quickly, and so the client can occupy or let the building earlier. Consequently, there are savings in land, labour, rents, overheads and financing costs, and a faster return on investment. Furthermore, if less time is needed on site, then there is less pressure on the design team to find a suitably lengthy „weather window“ for construction activities (Glass, 2010).

The very existence of a precast concrete industry and the numerous successful building projects achieved using precast concrete, for the whole or just a part of the structure, is proof that the technique is practical and economical (Elliott, 2002).

This research is not going to change already existing quality polices, but will reinforce the performance of Quality control practices in the concrete manufacturing industry in Ghana.

Finally, results obtained from this research will assist future efforts to develop and build a strong Quality control management culture concrete producers in Ghana.

1.9 ORGANISATION OF THE THESIS

The research comprises of five chapters organised as follows:

Chapter one deals with the introduction to the research including, background to the study, statement of the problem, aim and objectives of study, scope of research, significance of study and organisation of the research. **Chapter two** is made up of relevant literature on the research topic. **Chapter three** addresses the research methodology adopted. It includes the research design, the sampling technique adopted and the method of data collection. **Chapter four** presents data analysis of the research work while **Chapter five** presents the proposed framework. **Chapter six** discusses the major findings, recommendations and conclusion of the study

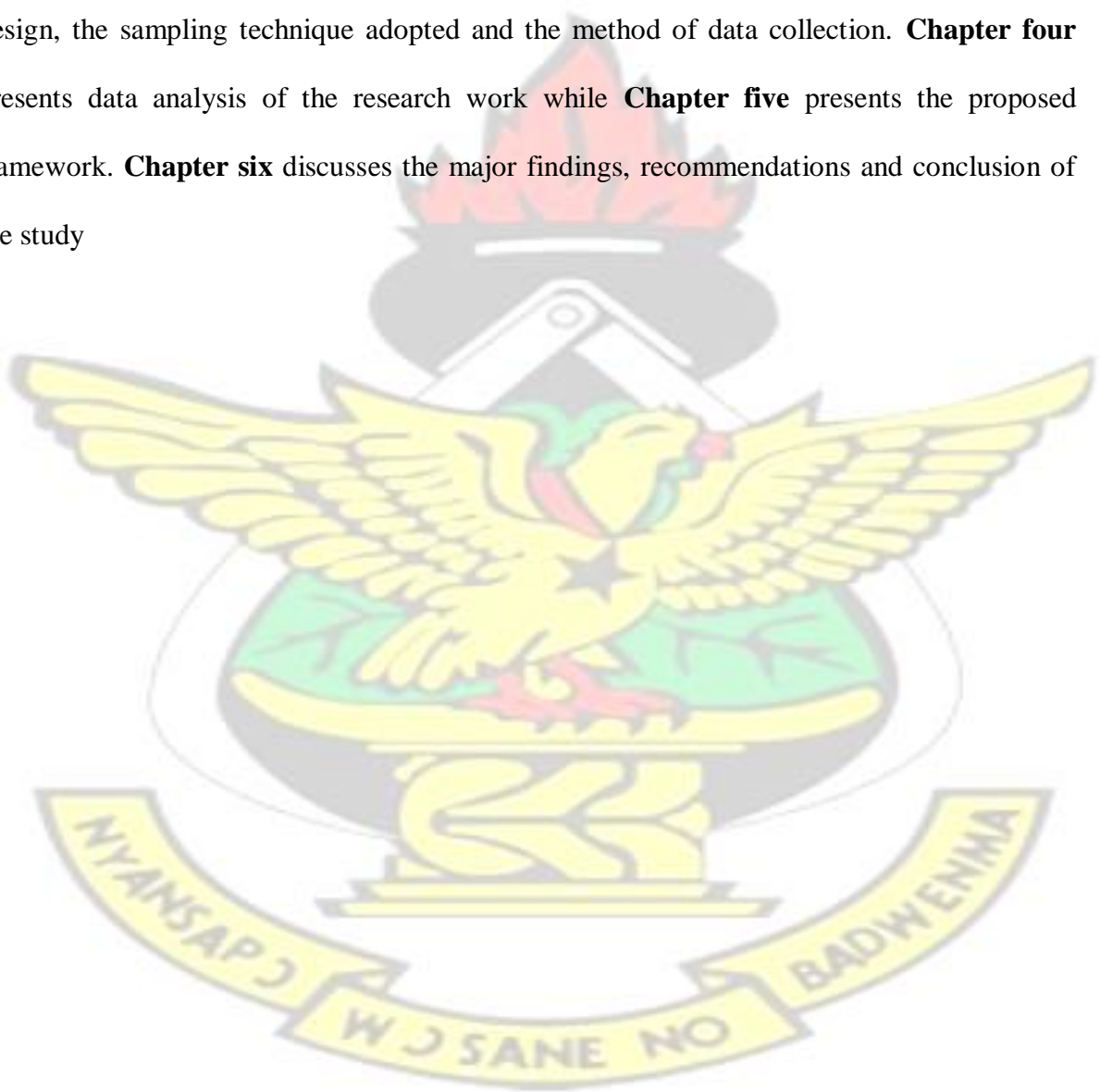

CHAPTER TWO

LITERATURE REVIEW

2.1 AN OVERVIEW OF THE GHANAIAN CONSTRUCTION INDUSTRY

In Ghana, the construction industry is faced with myriad of challenges, notably amongst them are excessive bureaucratic conditions, a weak material supply base, financial uncertainties, an unregulated labour market and poor management practices (AmoaMensah, 2002).

Notwithstanding these challenges, the construction industry has made significant contribution to both industrial output and overall Gross Domestic Product (GDP) in Ghana over the years. With reference to available country-wide statistics, the impact of the built environment sector as a whole is much greater; including segments of the manufacturing, mining, quarrying, electricity and water sectors (Osei, 2013).

From observations and reference to legal and regulatory documents, such as the Building Regulations (Republic of Ghana 1996), it suggests that the Ghanaian built environment sector is modeled on the UK regulatory system. The Ghanaian construction sector is akin to the UK construction sector about 20 years ago. There are serious shortfalls in materials handling, safe working practices, quality and timeliness of construction. Another widely applicable feature of the Ghanaian built environment sector, common to many developing countries, is that labour is comparatively cheap. This means that greater emphasis is put on selection of materials and components by price rather than might be expected in countries where there is a higher labour cost (Osei, 2013).

2.1.1 Construction Sector's Contribution to Gross Domestic Product

The Construction sector's share to overall Gross Domestic Product (GDP) has improved significantly over the past two decades. The sector's share as percentage of GDP was 7.6 % in 1996 and this improved to 8.5% of GDP in 1997. Due in part to the overall improvement in the macroeconomic landscape of the country as a result of the implementation of good macroeconomic policies, the sector's contribution to GDP rose steadily to 9.1 % of GDP in 2005 from 8.8% in 2004 (See Chart 2). The sector's share of GDP improved further 9.8% in 2007 from 9.3% recorded in 2006. Again, the construction sector's contribution to the overall economy picked up to 9.9% of GDP in 2011 from 9.4% of GDP registered in 2010 and which compares favorably with 1993-2011 period average of 9.1% of GDP (Osei, 2013).

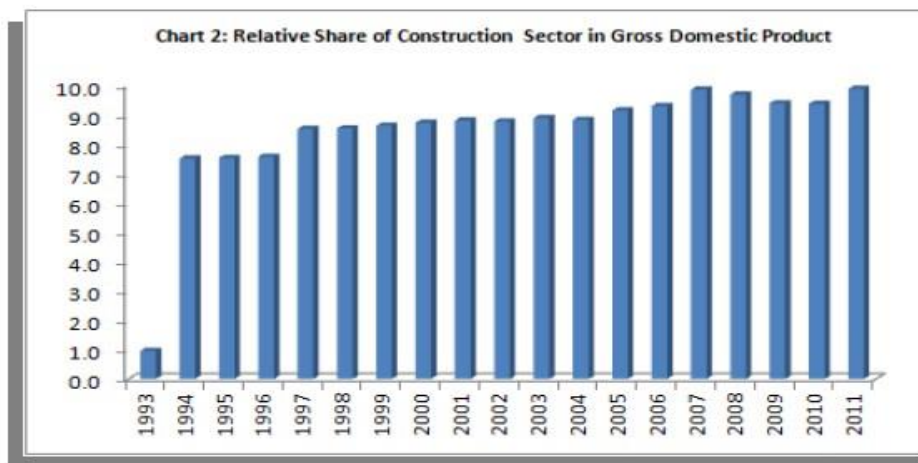

Figure 2.1 Relative share of the construction sector in gross Domestic Product Source:

Ghana Statistical Service as published by Victor Osei, 2013

2.2 CONCEPT OF CONCRETE PRODUCTION

2.2.1 Historical Overview

The time period during which concrete was first invented depends on how one interprets the term “concrete.” Ancient materials were crude cements made by crushing and burning gypsum or limestone. Lime also refers to crushed, burned limestone. When sand and water were added to these cements, they became mortar, which was a plaster-like material used to adhere stones to each other. Over thousands of years, these materials were improved upon, combined with other materials and, ultimately, morphed into modern concrete.

Today’s concrete is made using Portland cement, coarse and fine aggregates of stone and sand, and water. Admixtures are chemicals added to the concrete mix to control its setting properties and are used primarily when placing concrete during environmental extremes, such as high or low temperatures, windy conditions (McKnight, 2004).

The precursor to concrete was invented in about 1300 BC when Middle Eastern builders found that when they coated the outsides of their pounded-clay fortresses and home walls with a thin, damp coating of burned limestone, it reacted chemically with gases in the air to form a hard, protective surface. This wasn’t concrete, but it was the beginning of the development of cement (McKnight, 2004).

Early cementitious composite materials typically included mortar-crushed, burned limestone, sand and water, which was used for building with stone, as opposed to casting the material in a mold, which is essentially how modern concrete is used, with the mold being the concrete forms (McKnight, 2004).

As one of the key constituents of modern concrete, cement has been around for a long time.

About 12 million years ago in what is now Israel, natural deposits were formed by reactions between limestone and oil shale that were produced by spontaneous combustion. However, cement is not concrete. Concrete is a composite building material and the ingredients, of which cement is just one, have changed over time and are changing even now. The performance characteristics can change according to the different forces that the concrete will need to resist. These forces may be gradual or intense, they may come from above (gravity), below (soil heaving), the sides (lateral loads), or they might take the form of erosion, abrasion or chemical attack. The ingredients of concrete and their proportions are called the design mix (McKnight, 2004).

2.2.2 Definition of concrete

This is a mixture of cement, fine aggregate, coarse aggregate and water in simple proportions (Seeley, 1987). The proportions of each material control the strength and quality of the resultant concrete.

Cement and lime are generally used as binding materials, whereas sand is used as the fine aggregates and crushed stones, gravel, broken bricks are used as coarse aggregates in preparing concrete.

2.2.3 Aggregates:

There are gravels, crushed stones and sand which are mixed with cement and water to make concrete. The two most essential characteristics for aggregates are durability and cleanliness: the cleanliness includes freedom from organic impurities. Aggregates are classed as being either fine or coarse (Seeley, 1987).

Fine Aggregates: This consists of natural sand, or crushed stone or crushed gravel sand which will pass through a standard 5mm sieve with a good proportion of the larger particles.

Coarse Aggregate: This is primarily natural gravel or crushed gravel or stone that are retained on a standard 5mm British Standard Sieve.

Both types of aggregate should comply with the grading requirements of BS 882. Artificial coarse aggregates such as clinker and slag are used for lightweight concrete. The maximum size of coarse aggregate is determined by the class of work. With reinforced concrete the aggregate must be able to pass readily between the reinforcement and it rarely exceeds 20mm. For blinding foundations and mass concrete work the size can be increased possibly up to 40mm. The type of aggregates used directly influences the strength qualities of the concrete (Seeley, 1987).

In making concrete, aggregates must be graded so that the smaller particles of the fine aggregates fill the voids created by the coarse aggregate. The cement paste fills the voids in the fine aggregate therefore forming a dense mix.

2.2.4 Water

The water used in the making or mixing of concrete must be clean, free from impurities which could affect the concrete. It is usually specified as being of a quality fit for drinking. A proportion of the water will set up a chemical reaction which will harden the cement. The remainder is required to give the mix workability and will evaporate from the mix while it undergoes curing, leaving minute voids. An excess of water will give a porous concrete of reduced durability and strength.

2.2.5 Cement

Cements are substance which bind together the particles of aggregates (usually sand and gravel) to form a mass of high compressive strength. The most commonly used cement is Portland cement which may be of the ordinary variety or be rapid-hardening. There are several other cements that will produce concretes with more specialized properties.

Portland cement which is the main binding material in concretes is made by mixing together substances containing calcium carbonate, such as chalk or limestone, with substance containing silica and alumina, such as clay or shale, heating them to a clinker and grinding them to a powder. The basic requirements for Portland cement cover composition, sampling procedures and tests of fineness, chemical composition, compressive strength, setting time and soundness. The cement combines with water to form hydrated calcium silicate and hydrated calcium aluminates. The initial set takes place in about 45 minutes and the final set within ten hours, and develops strength sufficiently rapidly for most concrete work (Seeley, 1987).

2.2.6. Curing

The chemical reaction which accompanies the setting of cement and hardening of concrete is dependent on the presence of water therefore curing is the process of preventing the loss of moisture from the concrete while maintaining a satisfactory temperature regime. The hardening of concrete, the development of the strength and impermeability depend on the presence of water.

At the time the concrete is placed, there is always an adequate quantity of water present for full hydration, but it is necessary to ensure that this water is retained so that the chemical reaction continues until the concrete has developed the necessary degree of permeability and

strength. Therefore, the exposed concrete should be covered with bubble plastic sheets or quilts of plastic with fibres, glass wool, straw or other suitable material, to protect it from the sun and drying winds for at least seven days.

There are two types of curing namely;

1. By keeping water or moisture in close contact with the surface of the concrete through spraying or sprinkling damp sand and damp hessian.
2. By leaving the formwork in place and sprayed-on curing membranes

2.2.7 Site Testing of Materials

After all the materials have been delivered to the site, it is sometimes necessary to carry out site tests on the materials to determine their suitability. The following tests relating to cement and sand serve to illustrate the approach (Seeley, 1987).

Cement

1. Examine to determine whether it is free from lumps and is of a flour-like consistency that means it is free from dampness and it is reasonably fresh.
2. Place hand in cement and if blood heat then it is in satisfactory condition.
3. Settle with water as paste in a closed jar to see whether it will expand or contract.

Sand

1. Handle the sand; it should not stain hands excessively, ball readily or be deficient in coarse or fine particles.
2. Use a standard sieve test – if more than 20 percent is retained on a 1.25mm sieve, it is unsuitable for use.

3. Apply silt or organic test; a jar half filled with sand and made up to the three-quarters marks with water; shake vigorously and leave for three hours; the amount of silt on top of the sand is the measured and this should not exceed six percent.

KNUST

2.2.8 Concrete Mixes

Concrete must be strong enough when it has hardened, to resist the various stresses to which it will be subjected and it often has to withstand weathering action. When freshly mixed, it must be of such a consistency that can be readily handled without segregation and can easily be compacted in the formwork. The fine aggregate (sand) fills the interstices between the coarse aggregate and both aggregates need to carefully be proportioned and graded. The strength of concrete is influenced by a number of factors (Arora and Gupta, 2003).

These factors include:

1. Proportion and type of cement;
2. Type, proportions, grading and quality of aggregates;
3. Water content;
4. Method and adequacy of batching, mixing, transporting, placing, compacting and curing the concrete.

Concrete can be mixed by hand or machine on the job or purchased ready mixed, when it is delivered to the site from a central batching plant in Lorries with mixing drums or with revolving containers. Hand mixing should only be used for limited quantities of concrete on the smallest jobs, with the proportion of cement increased by ten percent (Seeley, 1987). The materials are mixed dry on clean, hard surface, water added and further mixing continued until a uniform colour is obtained.

Concrete mixers are designed by their capacity of concrete and type (tilting, non-tilting and reversing). The normal mixing time is at least one minute after all materials, including water, have been placed in the mixer.

Concrete mixes can be specified by the volume or weight of the constituent materials or by the minimum strength of the concrete. Nevertheless, the strength of concrete produced under site conditions varies widely. A more realistic approach is to specify a minimum strength of the concrete and for the proportions of cement, sand, coarse aggregate and water then to be selected to achieve it (Arora and Gupta, 2003).

The water/cement ratio is a most important factor in concrete quality. It should be kept as low as possible, consistent with sufficient workability to secure full compacted concrete with the equipment available on the site. The higher the proportion of water, the weaker the concrete will be. Water/cement ratios are usually in the range of 0.40 to 0.60 (weight of water divided by weight of cement). Allowance has to be made for absorption by dry and porous aggregate and the surface moisture of wet aggregate. Badly proportioned aggregates require an excessive amount of water to give adequate workability, and this result in low strength and poor durability. A common test for measuring workability on the site is the slump test, although for greater accuracy the compacting factor test or consist meter test should be used. The slump test consists of filling a 300mm high open ended metal cone with four consolidated layers of concrete and then lifting the cone and measuring the amount of slump or drop of the cone-shaped section of concrete. Slumps vary from 25mm for vibrated mass concrete to 150mm for heavily reinforced non-vibrated concrete (Arora and Gupta, 2003).

2.2.9 Reinforced Concrete

Reinforcement is generally in the form of steel bars which are used to provide the tensile strength which plain concrete lacks. The number, diameter, spacing, shape and type of bars

to be used have to be designed. Reinforcement is placed as near to the outside fibres as practicable, a cover of concrete over the reinforcement is required to protect the steel bars from corrosion and to provide a degree of fire resistance.

Plain cement concrete is strong in compression but weak in tension, whereas steel is equally strong in compression but weak in tension. A long steel bar can develop its full strength in tension but not in compression due to tendency of its buckling. Therefore, steel bars are embedded in cement concrete to take up tensile or excessive shear stresses (Arora and Gupta, 2003).

Concrete is strong in compression but weak in tension, and where tension occurs it is usual to introduce steel bars to provide the tensile strength which the concrete lacks to prevent structural failure. For example, with a concrete suspended slab in drainage structures, compression occurs at the top and tension at the bottom, so the reinforcement is placed about 25mm up from the bottom of the beam and the ends are often hooked to provide a grip. The 25mm cover prevents rusting of the reinforcement (Seeley, 1987).

The steel must be free from loose mill scale, loose rust, grease, oil, paint, mud and other deleterious substances which impair the bond between the steel and concrete. The most common form of reinforcement is the mild steel bars to BS4449 or BS 4482. Medium and high tensile bars are also available, and deformed bars which are twisted and/or ribbed provide a better bond and greater frictional resistance than round bars and obviate the need for hooked ends. It is important that the reinforcement is fixed securely to avoid displacement during the placing of the concrete (Seeley, 1987).

The bars are tied together with binding wire at intersections, and spacers of small pre-cast concrete rings or plastic fittings ensure the correct cover of concrete. For basis of drainage

structures, reinforcement may take the form of steel fabric to BS 4483, and this consists of a grid of small diameter bars, closely spaced and welded at the joints (Seeley, 1987).

2.2.10 Advantages and Disadvantages of Reinforced Concrete

Advantages:

- Its monolithic construction gives much rigidity to the structure.
- The structural members can be made of any desired strength.
- The constituents of reinforced concrete are easily available.
- It is impermeable to moisture.
- It is economical in ultimate cost since its maintenance cost is practically low.

Disadvantages:

- It requires skilled supervision and workmanship.
- It is heavier than steel construction for equal strength.
- It involves additional cost of formwork.
- The initial cost of reinforced concrete is high.

2.2.11 Types of concretes

Concretes are classified into different types as follows:

1. According to binding material used in the preparation of concrete.
2. According to design of concrete.
3. According to purpose of concrete.

1. Classification according to the binding material:

- a. Cement concrete

- b. Lime concrete

(Barry, 1996).

2. Classification according to design:

- a. Plain cement concrete
- b. Reinforced cement concrete
- c. Pre-stressed cement concrete

(Barry, 1996).

3. Classification according to purpose:

- a. High early strength concrete
- b. Vacuum concrete
- c. Air-entrained concrete
- d. Light weight concrete (Barry, 1996).

2.3 Introduction to Precast Concrete

For the better part of the last century, architecture has evolved and changed in many case for the better. Buildings could be built taller, larger, and structurally more sound based on a number of innovations. One such innovation was the invention of pre-cast concrete forms. Initially standard concrete in appearance, these forms have morphed into designer structures. They do not only provide structural support and strength, but are often times used in modern architecture to provide innovative design to the appearance of the building to which they are adhered.

Below will be a brief overview of the history, uses for both yesterday and today, as well as where those creating and utilizing precast concrete look to take it in the future.

2.3.1 History of Precast Concrete

The History of Precast Concrete Forms and its Innovations can be traced back as far as the Ancient Roman Era in which the Romans, looking for ways to strengthen their infrastructure throughout the empire, came across concrete as a suitable material to carry out their architecture design plans. Soon thereafter, they began developing forms allowing them to shape the concrete into many sizes and use them throughout their building process. Many of the ancient Roman infrastructures such as their aqueducts, culverts and tunnels were built on the back of this precast innovation. Although not referred to as “precast” by Caesar and his legions, this was the first recorded information of this type of structural design.

Initially accredited with the official precast concrete design in 1905, Liverpool, England city engineer, John Alexander Brodie, was the first to develop and perfect the idea of using precast concrete forms in modern architectural design. Oddly enough, although the use of precast forms took off at an unbelievable pace throughout Eastern Europe, its uses in British architecture never really gained any traction.

As precast concrete moved forward in its evolution, the innovation of pre-stressing these concrete forms came about allowing for much stronger, more durable forms. What prestressing does is, it lays the concrete in the form over stressed cables and allowed to set up. These cables are stressed by stretching them extremely tightly. Once the concrete is hardened and cured, the cables are then cut allowing them to pull back to somewhat of their

initial shape. Because the concrete is hardened around them though, this retraction is minimal. Minimal as it may be though, it does retract enough to pull the concrete together even more. That is what provides the form its strength and durability.

In addition to strength and durability pre-stressing concrete provides, it is also watertight and due to its structural integrity can hold up to extremely heavy workloads without issue. These pre-stressed forms are also considered crack-free. They will only not remain water tight, but also maintain their overall aesthetic design under any condition.

Another innovation seen throughout the precast concrete industry over time is the use of what is known as hollowcore products. This design uses far less concrete to make up the final product, and actually, in line with its name, is hollow in the center. Hollowcore is an improvement on the previously mentioned pre-stressed precast in that it still uses the prestressed philosophy for strength, however tubes, generally measuring between two-thirds to three fourths inches, are also run through the middle of the forms and then removed once the forms have cured. This provides the hollowcore forms the strength and structural integrity provided by pre-stressed forms, while also making them much lighter in the process. In addition, whereas precast concrete as a whole is a very green product already, having to use much less material in its creation, makes hollow core products among the greenest within the precast industry. The last innovation realized within the history of precast is the use of multiple aggregates in an effort to provide innovative and cutting edge designs in how the exteriors and in some cases, interiors of a building appear. Although still structurally sound in their design, many businesses are using varying design levels of precast concrete forms for their buildings signs, storefronts, or architectural structures within their buildings (McKnight, 2004).

2.3.2 The Many Uses of Precast Concrete

There are many different uses for precast concrete, whether it be for structural integrity or simply aesthetic design. To cover them all may be impossible within this limited amount of space, however, here are some of the main uses for each of the precast concrete innovations discussed earlier.

Basic pre-stressed concrete forms are designed for hundreds, if not thousands of uses. Due to its overall strength and durability, these forms are used throughout the world, however; typically find the bulk of their use in low-seismic zones throughout the planet. Strong and durable, earthquakes, aftershocks and tremors of larger magnitudes may place the structural integrity of precast concrete at risk. That being said, because these forms are already set upon delivery to the building locations in which they are used, they allow for the construction to move much more quickly given there is not the set up and cure times for concrete poured on site.

In addition, because of their strength and ability to handle increased workloads, the use of precast concrete has been seen widely throughout the use of skyscrapers, taller buildings and apartment complexes. That is not to say though that the structure itself has to be a high-rise office building or an apartment complex. Many precast concrete projects are found within residential homes, and due to its eco-friendly nature, they are becoming very popular in new home builds and renovations of older homes alike.

For example, whereas there has been a rise in the popularity of granite countertops over the past decade, one of the newest innovations seen in residential kitchen design is precast concrete countertops. These countertops can be poured with a varying number of aggregates,

and stained to match any kitchen design. In addition, some countertops are poured with the sink already in place too, making the sink basin itself a precast concrete structure.

Another great example of precast being utilized in the residential sector is using them for garage floors, especially when there is an under garage beneath the main one. Because these forms are as structurally sound as they are, parking two to three vehicles on top of them is never a problem. In many of these cases, because of its durability and lightweight, hollowcore forms are utilized for these flooring needs. Again, this saves the contractor from pouring a standard concrete slab and waiting for it to set up prior to building. In addition, if there were another room below the garage, additional structures would have to be built to ensure the ceiling of the lower area held true. Once set in place and secured, the builders can get right to work on putting the garage into place.

The other great thing about using these hollowcore forms as a garage floor is that should there be a second garage or storage area underneath the original garage, the precast hollowcore slabs not only serve as the floor to the main garage, but also serve as the ceiling to the lower garage or storage area.

Although many of the previously mentioned designs are utilized for appearance and residential use, there are also a number uses for precast concrete which are never even seen by the public. Many of the planet's sewer systems are built primarily from precast concrete forms. Although starting as aqueducts and culverts in Roman times, these sewer systems offer the structural stability required by their heavy usage, but also, being watertight, ensure the contents of the sewer system remain in the sewer, and not escaping into the environment through which they run.

Another use for precast concrete that benefits both residential and commercial users alike is the use of sound barriers along high traffic areas. In many major cities throughout the world where highways and interstates run through heavily populated areas, the noise can be nearly unbearable for residents along those thoroughfares. Because of that, many cities have employed these precast structures along these transit systems to serve as a sound barrier keeping the decibel level for the residents at a minimum. Furthermore, this also ensures those living along these roadways are kept safe from the high-speed travelers using them on a daily basis.

Finally, there are additional specialized uses for precast concrete forms that may not always be thought of, but are also growing in popularity with time. One example is the use of precast concrete in cemetery projects. Whether it is the building of mausoleums or above ground crypts, or precast headstones, in the past these were created by hand and chiseled out as needed. Today, thanks to precast concrete forms coming in numerous shapes and sizes, this is making these tasks all the easier.

Many of the precast concrete forms today are also found below the surface of ponds, lakes, rivers and oceans. Used as footings for docks, bridges, off-shore oil rigs and many other structures that find their base below the water's surface, these forms are great for being precast and transportable to the body of water in which they will soon be set. Again, the strength and durability of these precast structures allows them to perform as well under the surface as they do above it (McKnight, 2004).

2.3.3 Merits of Precast

The very existence of a precast concrete industry and the numerous successful building projects achieved using precast concrete, for the whole or just a part of the structure, is proof that the technique is practical and economical (Elliott, 2002).

Structures with a high degree of modular coordination and repetitive grids are ideal for precast construction. Precast construction allows mass production. Better methods can be adopted in factories leading to speedy production and economic of scale. The advantages in productivity and lower unit price make precast construction welcomed in many recent projects. As precast modules are made under controlled conditions with close supervision, there can be a higher level of consistency, accuracy and quality. In addition, unique shapes and designs as well as various finishing effects can be achieved.

Precast construction always groups similar work tasks for batch processing so that there is less material wastage as compared to conventional in-situ construction methods. Since major fabricating processes are carried out off-site in precast construction, there is less wet trade in the construction area.

The site can be neater and tidier, which is easier for site planning and space management. Reduction in site work also minimizes weather influence on the construction schedule. As a result, savings in construction time, manpower resources and a safer working environment can be achieved.

2.4 CONCEPT OF QUALITY CONTROL AND QUALITY MANAGEMENT

2.4.1 History and Evolution of Total Quality Management (TQM)

Quality control as known today did not exist in the eighteenth and nineteenth centuries. However, some quality control activities would be performed informally by individuals at workshop level (Garvin, 1988). The development and evolution of Quality Control started during and spanned the entire twentieth century (Feigenbaum, 1983). In 1913, JC Penney became one of the earliest people who presented the fundamentals of Total Quality Management philosophy when he suggested concepts such as ;customer satisfaction, fairness, quality, value, associate training, and rewards for performance to be managerial bases for a business (Jablonski, 1994). Furthermore, Fredrick W. Taylor who is known as the „father of scientific management“ presented other quality concepts in the early 1900s as well (Garvin, 1988).

Anyone tracing the development of TQM throughout the twentieth century, may easily notice the gap between TQM development as a theory in literature as opposed to TQM development in practice and implementation particularly in the USA notwithstanding that is where it originated (Kinlaw, 1992). For example, it took more than fifty years for Walter A. Shewhart's (a physicist with Bell Telephone Laboratories, the birth place of the American quality), teachings in the book “The Economic Control of Quality of Manufactured Product” published in 1931 to be recognized and implemented in the USA (Kinlaw, 1992). Nevertheless, the development of the approach to quality control in the USA went through four broad stages: operator quality control, inspection quality control, statistical quality control and total quality control (See Fig. 2.2)

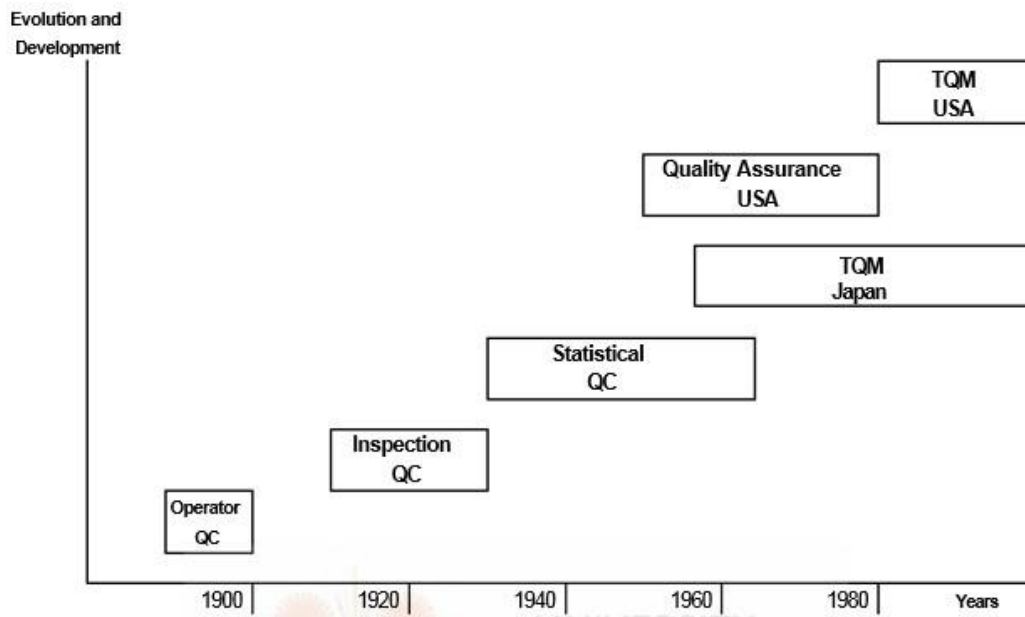

Fig. 2.2: Evolution and Development of Quality Control

(Feigenbaum, 1983)

2.4.2 Operator Quality Control

Up to 1900 when goods were produced in small volumes, quality control activities were performed by artisans and skilled craftsmen (Garvin, 1988). That period of time in the quality control movement is termed the Operator Quality Control Era (Feigenbaum, 1983). Some features of this era were that, quality control was performed mainly in the product manufacturing field and was not a responsibility assigned to an independent person. However, the operator performed quality control as part of his job.

When one goes back, however, to the early 1800s, a breakthrough in this field may be acknowledged when a rational gauging system was put in place. Under the setup, a model of a product is kept from use as it serves as a standard for measuring the degree of conformity

of subsequent output (Garvin, 1988). Another innovative idea in the field of quality was the 1819 proposal of introducing the inspection concept to control product quality, though not formally adopted and recognized immediately.

2.4.3 Inspection Quality Control

Inspection quality control may be the first directly linked concept to TQM that ever was formally introduced. In the early 1900s Fredrick W Taylor gave this concept more acceptance by singling it out as a task for bosses to manage their businesses effectively (Garvin, 1988). Enhancing Taylor's idea in 1922, G.S. Radford published the book „The Control of Quality in Manufacturing“ in which he clearly stated the direct link between inspection activity and quality control. All these efforts have pushed inspection concept to become formally linked to quality control and to be part of management whereas it is performed on an independent basis, to the extent that by 1924, for example, a department for inspection engineering was established at Western Electric (Garvin, 1988). However, products during this stage was not yet produced in huge volumes, therefore, 100% inspection i.e. inspection for all units of production was conceivable (Feigenbaum, 1983).

2.4.4 Statistical Quality Control

A statistical theory was originated over 80 years ago by Sir Ronald Fisher. (Jablonski, 1994). Shewhard pioneered a breakthrough of statistical quality control (SQC) through his publication in 1931 based on statistical principles (Garvin, 1988). He realized in a single volume that in any work process there would be natural variation such that limits should be specified to distinguish acceptable product fluctuating within these two limits (Kinlaw, 1992). Then, Shewhard was working within a team at Bell Telephone Laboratories at Western Electric, where they had a programme for nationwide telephone network standardization and

uniformity, the challenge they faced was how to extract big amounts of information regarding units' quality from a section of inspection data. Consequently, some statistical techniques such as sampling, control charts and using prediction and probability rules were adopted and developed (Garvin, 1988).

Another challenge that prompted the use of SQC was the mass production that was required for World War II (Feigenbaum, 1983) when the ordnance department of the USA Army faced a problem of getting large quantities of arms from different suppliers at an acceptable level of quality (Garvin, 1988). Another contributor to this field was E.W. Deming. He added to Shewhard's work and developed his own version of SQC. All in all, by the late 1940s, inspection that was based on statistical techniques had become the primary method of control quality (Garvin, 1988)

2.4.5 Total Quality Control

The concept of TQC grew rather slowly in the USA (Kinlaw, 1992) although many TQC aspects were developed in the USA in the 1950s. Quality was implemented in the American and European industries only in the 1980s (Kinlaw, 1992). The reason for this according to Feigenbaum's opinion was that prior to that, there was no „willingness or the ability of business and governmental organizations to take adequate steps concerning the findings of technical and statistical work“ (Feigenbaum, 1983). He continues by saying that „the quality problem could not be handled by existing decision making structures.“ In other words, quality control still was seen as a duty for inspection group or statistical quality control coordinator at the shop-floor level. However, this level of the decision-making structures could not comprehend the quality problem broadly and this excluded the involvement of the management system and the administration work in the quality problem. On the other hand,

Japanese quality before the 1940s was limited to inspection quality. Even the SQC approach was limited to a small group of experts (Garvin, 1988). However, the post-war era saw dramatic progress in the Japanese quality, and that happened over a relatively very short period of time (Kinlaw, 1992). In fact, quality control was introduced to Japanese by some American experts (Garvin, 1988).

The most well-known expert who contributed to Japanese quality is W. Edward Deming (Garvin, 1988). He was invited to Japan in 1950 to deliver a series of lectures on SQC (and the system of production) to the leaders of Japan industry (Deming, 1994). Other experts such as Joseph M. Juran followed Deming's footsteps in 1954 and presented seminars on the system of total quality management in organizations (Garvin, 1988). Their contributions influenced the Japanese dramatically (Deming, 1994). Basically, the 1950s became a watershed era in the Japanese transformation from „copier“ to quality leaders. (Jablonski, 1994).

The Japanese realized the special need for an own approach to quality. In this regard, they initiated an effort in 1956. In 1962, the Japanese had innovated the concept of quality control circle (Ishikawa, 1984) By 1968 they had developed their own version of TQM, and presented it as Company Wide Quality Control (CWQC) (Ishikawa, 1985) and the most prime aspects of TQM were perfected in Japan between 1950-1965 (Galgano, 1994).

Quality control progress in the USA took a different route and initially less momentum than the Japanese one. The 1950s had seen invaluable theoretical contribution. For instance, the publication 'Quality Control Handbook' by J.M Juran in 1951, tackled the economics of quality (Garvin, 1988). In addition, during 1956 A.V Feigenbaum proposed a comprehensive approach to quality in his publication „Total Quality Control“ (Garvin, 1988).

On the quality concepts implementation side, in 1961-62 Martin Company took a new step by adopting a programme called Zero Defect (ZD) rather than the concept of Acceptable Quality Levels (AQL) that had been proposed by the war department in the 1942. The program ZD was based on quality principles such as: workers motivation and training, as well as the idea of being the ZD becoming an achievable objective (Garvin, 1988). In fact, some authors termed the period of the two decades of 1950s and 1960s of quality control movement as Quality Assurance (Garvin, 1988).

In the early 1980s, the Americans felt the gap between quality of their products and the Japanese ones (Jablonski, 1994). They realized that quality is a crucial factor for business success in the modern international business environment (Feigenbaum, 1983).

Subsequently, the TQM approach begun to be adopted in the 1980s, as part of managerial strategies in the USA and European industries as well as in the service sector and government (Galgano, 1994: xiv). In the late 1980s major aspects of TQM had been integrated (Jablonski, 1994). A later dimension added to TQM related to emerging environmental and health issues. Today, it is noticeable that most leading companies have adopted TQM programme (Galgano, 1994).

2.5 THE MEANING OF QUALITY

The dictionary gives a long list of the meanings of the word „quality“ many of which are subjective (Peach, 1997). However, some of the meanings of quality as applied in the field of management in general and manufacturing in particular are examined in this section.

Garvin (1988) discusses the term quality, where he dedicates three chapters of his book in an attempt to offer a comprehensive meaning for quality. He begins the third chapter of his book with a conceptualization of the term „quality“ by raising questions of whether quality can be a subjective term or an objective one; absolute or relative; and what its relationship with

variables such as price, cost, productivity and market share is. He then categorizes most of the definitions into five principal groups namely: the transcendent, product-based, user-based, manufacturing-based and value-based (Garvin, 1988).

KNUST

Table 2.1 Examples of Defining Quality

Group	Definitions
<i>Transcendent</i>	<ul style="list-style-type: none"> • “Quality is neither mind nor matter, but a third entity independent of the two ... even though Quality cannot be defined, you know what it is.” (Robert M. Pirsig, Zen and the Art of Motorcycle Maintenance [New York: Bantam Books, 1974]) • “. . . a condition of excellence implying fine quality as distinct from poor quality.... Quality is achieving or reaching for the highest standard as against being satisfied with the sloppy or fraudulent." (Barbara W. Tuchman, "The Decline of Quality," New York Times Magazine, November 2, 1980)
<i>Product-based</i>	<ul style="list-style-type: none"> • "Differences in quality amount to differences in the quantity of some desired ingredient or attribute." (Lawrence Abbott, Quality and Competition [New York: Columbia University Press, 1955]) • "Quality refers to the amounts of the unpriced attributes contained in each unit of the priced attribute." (Keith B. Leffier, "Ambiguous Changes in Product Quality," American Economic Review, December 1982,)

<i>User-based</i>	<ul style="list-style-type: none"> • "Quality consists of the capacity to satisfy wants. (Corwin D. Edwards, "The Meaning of Quality," Quality Progress, October 1968,) • "In the final analysis of the marketplace, the quality of a product depends on how well it fits patterns of consumer preferences." (Alfred A. Kuelm and Ralph L. Day, "Strategy of Product Quality," "Harvard Business Review, NovemberDecember 1962,) • "Quality is fitness for use. (J. M. Juran, ed., Quality Control Handbook, Third Edition [New York: McGraw-Hill, 1974,)
<i>Manufacturing-based</i>	<ul style="list-style-type: none"> • Quality [means] conformance to requirements. " (Philip B. Crosby, Quality Is Free [New York: New American Library, 1979],) • "Quality is the degree to which a specific product conforms to a design or specification." (Harold L. Gilmore, "Product Conformance Cost," Quality Progress, June 1974,)
Group	Definitions (Cont'd)
<i>Value-based</i>	<ul style="list-style-type: none"> • "Quality is the degree of excellence at an acceptable price and the control of variability at an acceptable cost." (Robert A. Broh, Managing Quality for Higher Profits [New York. McGrawHill, 1982]) • "Quality means best for certain customer conditions. These conditions are (a) the actual use and (b) the selling price of the product." (Armand V. Feigenbaum, Total Quality Control [New York: McGraw-Hill, 1961], p.1)

For more convenience, out of these five approaches for defining quality, an elaboration will be made on two of them, namely: manufacturing-based and user-based definitions.

2.5.1 Manufacturing-Based Definitions of Quality

Manufacturing-based definitions of quality look at quality from a manufacturing viewpoint, where pre-determined requirements, design activities and manufacturing practices are the

bases of quality product and accordingly, the quality definition will be „conformance to requirement“ (Crosby, 1990).

Crosby argues that this definition offers practical meaning for quality. In addition, it considers that zero-defect product is the only acceptable quality level since 100 percent conformance to requirements is the only acceptable quality measure. However, it is management's prime responsibility to create the right requirements in order to meet customer real needs (Crosby, 1990).

On the other hand, Juran (1992) finds the definition of quality to be „conformance to specifications“ or „conformance to standards“. This is a problematic definition when applied at managerial levels as a product is meant to meet customer needs while a conformance to specifications is just one of many means for achieving that objective on the part of the manufacturer. Furthermore, standards and specifications are static while „quality is a moving target.“ Lawton (1993) supports Juran's observation by mentioning that, requirements are often specified by the producer who „may have only a partial relationship to customer desires.“

Gavin (1988) realizes this criticism when he says that the definition „conformance to specifications“ considers that the product, which is of customer's interest and deviates from specifications is likely to be described as poor quality product, as such, this would be a serious problem in that definition of quality.

All in all, as ISO 9000-1 notes that specification, in itself might not guarantee that a customer's requirements are met (Peach, 1997).

2.5.2 User-Based Definitions of Quality

User-based definitions of quality, view quality from the customer side. The quality of the product is determined by the user or by the customer (Feigenbaum, 1983). Hence, the product

which is regarded as having the highest quality is the one, which best satisfies customer's preferences (Garvin, 1988). A popular definition underlying this approach is the one by Juran (1989) where he defines quality as „fitness for use.“ He then identifies two dimensions of quality namely: product features that meet customer needs and freedom from deficiencies. However, Garvin points out basic problems with the user-based approach and this equates quality with maximum customer satisfaction: though related, they are not identical.

In addition, in order to achieve satisfaction from wide range of customers, it would be practically difficult to comprehend varying individual preferences and to transform those into a „meaningful definition of quality at the market level.“ Besides, by considering quality to be exclusively customer determined, the product's impact on the environment, health, safety and social concerns are not explicitly addressed. In the case where these concerns are considered, it would be at individual level only.

2.5.3 Comprehensive Approach for a Definition of Quality

Juran (1992) reports that to date, there is no consensus on the adoption of a simple comprehensive phrase to describe quality. Garvin (1988) goes further in pointing out the potential conflict that exists between members of marketing, engineering and manufacturing departments within an organization due to them holding different views of what constitutes quality. Marketers tend to see quality from the customers viewpoint; hence, their concern is what happens to the product outside the factory. Engineers in general, focus mainly on specifications and how to translate product performance into precise measurements while manufacturing departments would look at the meaning of quality from a different standpoint altogether. They would tend to prefer the practical meaning of quality i.e. „conformance to specifications“ and doing things right the first time while reducing waste.

These three approaches are not unified. Therefore, a serious problem in communication may exist within an organization. However, an organization can take advantage of these dissimilar perspectives of quality in order to enhance its position, as this would be an adoption of a comprehensive meaning of quality rather than the pursuit of satisfying a particular definition of quality. In supporting Garvin's findings, Galgano (1994) states that „quality becomes a comprehensive and unifying concept.“ He goes further by relating the internal structure of the organization to the quality concept itself. Moreover, he considers quality to be a changing concept increasing constantly over time.

2.5.4 Quality Dimensions

The comprehensive approach sets the quality concept as a base and a goal for all operational and organizational activities undertaken (Galgano, 1994). Therefore, quality should be a multi-dimensional concept with keeping customer satisfaction as the focal point.

Nevertheless, the main quality dimensions are briefly presented below:

- *Operational Dimension:* Operational dimension of quality deals, mainly, with engineering, manufacturing and quality of outputs such as: specifications, conformance, product features, and delivery service and product quality.
- *Reliability Dimension:* Reliability dimension may include durability, serviceability maintainability.
- *Economical Dimension:* Economical dimension of quality is concerned with balancing between quality value and quality cost for each quality characteristic (Juran, Sedar and Gryna, 1962). Factors such as cost, productivity, profit and competitiveness fall into this dimension.

- *Organizational Dimension*: The organizational dimension deals mainly with quality of organizational structure and performance.
- *Social and Environmental Dimensions*: Social and environmental dimensions are quality characteristics regarding these dimensions within and outside the organization such as moral, safety, internal customers' interest, waste, pollution and so on.

While considering the meaning of quality to be customer satisfaction-oriented, the following notes should be taken into account:

- Both the internal and external customers should be satisfied and the stockholders' interest should be recognized.
- When specifying customer needs, those needs may be expressly stated by customer or implied (latent) needs that a customer expects to be fulfilled (Peach, 1997).
- Quality activity may constitute one of two broad efforts. Firstly, it may involve the elimination of negative features of quality such as non-conformance to requirements. This is sometimes called negative quality or reactive quality because the organization responds to a negative situation. The aim of reactive quality is to reduce customer dissatisfaction. The other category of quality activities basically aims at increasing customer satisfaction by as an example, improving a product or service. This kind of quality is also termed positive quality (Galgano, 1994).
- Quality is customer-oriented. However, other quality factors are essentials to the quality concept as well. Each product might have its own array of quality factors (Ozeki and Asaka, 1990). What is fundamental is the right combination of factors in a balanced manner in order to achieve customer satisfaction as well as producing a quality product (Galgano, 1994).

All in all, quality in the management field has been broadened to cover other meanings of product quality. Basically, it embodies all aspects of excellence that ensure the production of a quality product and achieving customer satisfaction. Furthermore, quality aspects may be grouped into three broader fields namely, quality of output, quality to satisfy customer and organizational and operational quality.

- Quality output looks at process output and results measured against pre-specified quality characteristics, requirements and standards.
- Quality to satisfy internal and external customers.
- Organizational operational quality, which mainly is concerned with an organizational structure and culture as well as conducting managerial functions that achieve quality. Included under this field are engineering, manufacturing, marketing and administration activities.
- Quality activity may constitute one of two broad efforts. Firstly, it may involve the elimination of negative features of quality such as non-conformance to requirements. This is sometimes called negative quality or reactive quality because the organisation responds to a negative situation. The aim of reactive quality is to reduce customer dissatisfaction. The other category of quality activities basically aims at increasing customer satisfaction by as an example, improving a product or service. This kind of quality is also termed positive quality (Galgano, 1994).
- Quality is customer-oriented. However, other quality factors are essentials to the quality concept as well. Each product might have its own array of quality factors (Ozeki and Asaka, 1990). What is fundamental, is the right combination of factors in a balanced manner in order to achieve customer satisfaction as well as producing a quality product (Galgano, 1994).

2.6 TOTAL QUALITY MANAGEMENT PRINCIPLES

Before going further in describing TQM, it is important to discuss the philosophical principles of TQM. TQM is a managerial methodology. Therefore, it is a framework of principles as well as a systems approach. It is a philosophy trying to analyse what factors influence business quality, as well as tools with which quality can be controlled and assured. There are different approaches that can be adopted to achieve quality, but all these approaches lie under one methodology. The following concepts form part of the principles of TQM and its philosophy:

a) Quality Integration

Organization starts its business by identifying customer needs, passes through design to manufacturing then inspection. The last step will be marketing and selling.

This is the traditional way of doing business. At the end of the day, management wishes to present a quality product and to enhance its competitive position. Questions that arise about this sequence are: how can management assure quality and where does quality fit in the sequence. TQM philosophy is that quality cannot be achieved only by applying inspection at the end of the process, rather it is a quality of conducting all these processes, and integrating all interdependent components to accomplish the goal of the whole organization. Ishikawa captures the spirit of TQM by saying: „Quality means quality of work, quality of service, quality of information, quality of process, quality of divisions, quality of people including workers, engineers, managers and executives, quality of system, quality of company, quality of objectives, briefly speaking, it is Total Quality, or as the Japanese call it, Company-wide Quality“ (Ishikawa, 1985).

b) Quality First

Management, continuously, wants organizations to produce good products at low cost, that is, to be competitive and to increase the market share, or at least, to survive and maintain the same level of market share. TQM aims at serving this purpose. However, management sometimes has the tendency to rather get short-run profit than long-run holistic organization advancement. Management that adopts „quality-first“ strategy will increasingly gain customer confidence. Sales increase gradually as a result and hence profit ultimately winning on the international market in the long-run (Ishikawa, 1985). In fact, Deming (1982) puts it clear by making a statement that: “productivity increases with improvement of quality.”

c) Customer Orientation

Customer satisfaction is the top priority for business and basic condition for success. Basically, there would be no business without the customer (Galgano, 1994). Therefore, quality management considers the customer as a basic value that guides an organization’s activities.

In addition, a customer need should form an essential input for the designing and production process and influences the decision-making process to the extent that Kotler (2000) turns the organization chart up-side-down by putting the customer at the top of the pyramid. So TQM directs that an organization’s objectives, structure and managerial process should be established in such a way that it serves the customer.

The customer can be outside the organization or within the organization. The customers outside the organization are the clientele while those within are the employees. Since an organization accomplishes a particular job in a network of interdependencies, an employee who receives an input, naturally, it is an output of the preceding process. In this

case, the employee is a customer of the predecessor (Jablonski, 1994). Both inside and outside customers play a major role to the organization's success. Therefore, Ishikawa (1985) proposes that, manufacturers must study the requirements of consumers and to consider their opinions when they design and develop a product.

d) Continuous Improvement

Continuous improvement is essential for the very survival of a company due to ever changing tastes of customers and pressures from competitors. Incremental and breakthrough improvements enhance productivity by decreasing costs and/or improving performance. Performance is enhanced through greater responsiveness, shorter cycle times for new products or services, better products, unique marketing, engineering or production strategies (Khan, 2003).

Organizations are living in a dynamic environment. Products are designed to satisfy customer needs, which are ever increasing. Three factors that shape today's business environment are, rising customer expectations, continuous advances in technology and competition. These force management to adopt a „continuous improvement“ strategy as a normal way of managing a business.

On the other hand, with organizations confronting challenges continuously, immediately responding to action is a real need. A plan for prevention of these problems from occurring in the first place is rather important. Moreover, a programme for upgrading machines, processes and tools as well as inventing new opportunities and developing products are essentials for achieving competitiveness. Therefore, continuous improvement must be viewed as a regular part of the organization's performance (Kinlow, 1992).

e) Prevention rather than Inspection

The traditional way of management is to do inspection at the end of the production process. This approach, as Ishikawa (1985) notes, was abandoned at a relatively early period in Japan. Some of the criticisms on this approach are listed below:

- Inspection is costly. Ishikawa reports that the ratio of inspectors to line workers in the West is up to an average of 15%.
- Inspection approach does not ensure product and process improvement. On the contrary, an inspection approach is an implicit suggestion of having a mistake somewhere in the process, and accordingly, the inspector must pick out defective products.
- The same problem will be continuously committed. By the 1980s, about a third of the work in the US economy consisted of redoing prior work because products and processes were not perfect (Juran, 1989).

Deming (1982) summarizes this idea by saying „inspection is too late, ineffective and costly.“ The TQM approach is to „do it right the first time“ rather than to react after the problem happened. Problem prevention can be assured by controlling all processes, discovering problems, identifying their root causes then improving the process in order to avoid the problems.

f) Factual-Based Decisions

Management continuously need to make decisions. In organizations not based on quality, decision-making is based on opinion or personal experience of designers, manufacturing engineers, inspectors, etc. in the absence of data (Juran, 1980). Then, blaming and finger pointing start to shift responsibility for any mistake.

Ishikawa (1985) proposes the following steps for conducting factual-based decision in order to ensure that any analysis has the right basis for decision-making:

- Clearly recognizing facts, then
- Expressing those facts with accurate data, and finally,
- Utilizing statistical methods to analyze the data

Facts can be properly identified by recognizing everyone involved in the process, within and outside the organization including: management, supervisors, workforce, suppliers and customers. All these individuals can contribute to a mutually benefiting solution. Of particular importance is the fact that their contribution relates to their field of concern (Jablonski, 1994).

g) Workforce Involvement

Juran (1989) defines workforce as all employees except the managerial hierarchy and „professional“ specialists. Traditional management tends to ignore workforce ability of participating in managerial activities. Galgano (1994) observes that workforce involvement is important when he writes „human beings have unlimited resources and immense capabilities.“ Galgano goes further in putting forward a condition for organization“’s ultimate success defined in terms of its management of human resources.

TQM requires that management must provide the workforce with knowledge and training, the workforce must understand the organization“’s objectives and processes as well as where their role fits in the organization so that they contribute efficiently in the improvement of the organization. Ishikawa (1985) explains one of the aspects of the Japanese approach to TQM as their insistence on having all divisions and employees involved in promoting quality

control in addition to quality control specialist. Moreover, Juran (1989) suggests that in order to achieve a quality workforce contribution, management should:

- motivate the workforce to make a contribution
- provide them with required training to enable them to make a contribution.

Juran goes on to say that the workforce can contribute in the following managerial aspects:

- Quality Control: This comes first because controlling is the dominant form of quality related responsibility assigned to the workforce.
- Quality Improvement: This comes after the contributions emanating from quality control.
- Quality Planning: This becomes the least the workforce can participate in.

2.7 TQM SYSTEM APPROACH

The battle of quality management to invade the business field is already over. Quality has now become an important factor for achieving economic success and organization's continuity (Lawton, 1993). Before proceeding in discussing the TQM system approach it may be useful to define what TQM is.

2.7.1 Definition of Total Quality Management (TQM)

After an elaboration of the meaning of the term quality has been made, it becomes relatively easy to define total quality management. TQM is a managerial approach that achieves the broad meaning of quality. Firstly, however, the meaning of the term „management“ is addressed. Crosby (1979) defines management as the function responsible for establishing the purpose of an operation, determining measurable objectives and taking the action

necessary to accomplish those objectives. Crosby mentions two specific responsibilities of management as establishing operation's purpose and measurable objectives as well as ranking necessary actions to accomplish those objectives.

Ozeki and Asaka (1990) define management as „planning and implementing controls for organised activities in a rational and efficient manner. „It therefore follows from these definitions that planning and control are central to management. However, Ozeki and Asaka break „controlling“ into a four-step cycle of plan-do-check-act, which is known as PDCA cycle. The postulation of (Ozeki and Asaka, 1990) is that repeated use of the PDCA cycle results in improvement. In other words, management's responsibilities according to the view of the two include three main aspects i.e. planning, controlling and improvement. In fact, Juran (1992) puts it clearer by mentioning that management covers three areas of process of planning, control and improvement in what he termed „Juran's Trilogy.“ Perhaps the plausible way in proceeding to define TQM at this stage is to define the term quality management. Juran (1989) defines quality management as the totality of ways through which quality planning, quality control and quality improvement are achieved.

It is also worthwhile to mention that quality management should not be seen in isolation from the general responsibilities of management. Rather, it should be seen as an integral part of the organization's overall system (Peach, 1997).

Once management adopts TQM as a strategy, however, certain arrangements should be done. Such arrangements are the subject of strategic quality.

2.7.2 Strategic Quality Management

Strategic quality management (SQM) is defined as a systematic approach for setting and meeting quality goals throughout the company (Juran, 1989). Once management decides to implement TQM, it is essential to make changes in certain arrangements within the organization's structure and culture. Juran (1989) suggests six major changes to apply in order to adopt managing for quality approach which are listed below:

- The establishment of broad quality goals as part of the company's business plan.
- The adoption of cultural change that is aligned with TQM philosophy.
- The rearrangement of priorities knowing that Quality first, customer satisfaction, employee participation and continuous improvement form part of the core of the foundation of TQM.
- Creating a new infrastructure to accommodate TQM requirements such as instituting a quality council and training facilities.
- Extensive training for the entire hierarchy.
- Upper-management participation in managing for quality.

Strategic quality management, basically, is concerned with setting an organization's quality objectives, mapping out the route and the means for reaching these objectives. It is about making necessary arrangements, TQM programme requirements and the practice of overall control.

As mentioned above, the main components of quality management are quality planning, quality control and quality improvement. Those components are briefly explained in the sections that follow.

2.7.3 Quality Planning

Quality planning is conducted to map out a route towards TQM. Juran (1989) definition for quality planning is that it is „the activity of (a) determining customer needs, and (b) developing the product features and processes required to meet those needs“ (see Fig. 2.3 below).



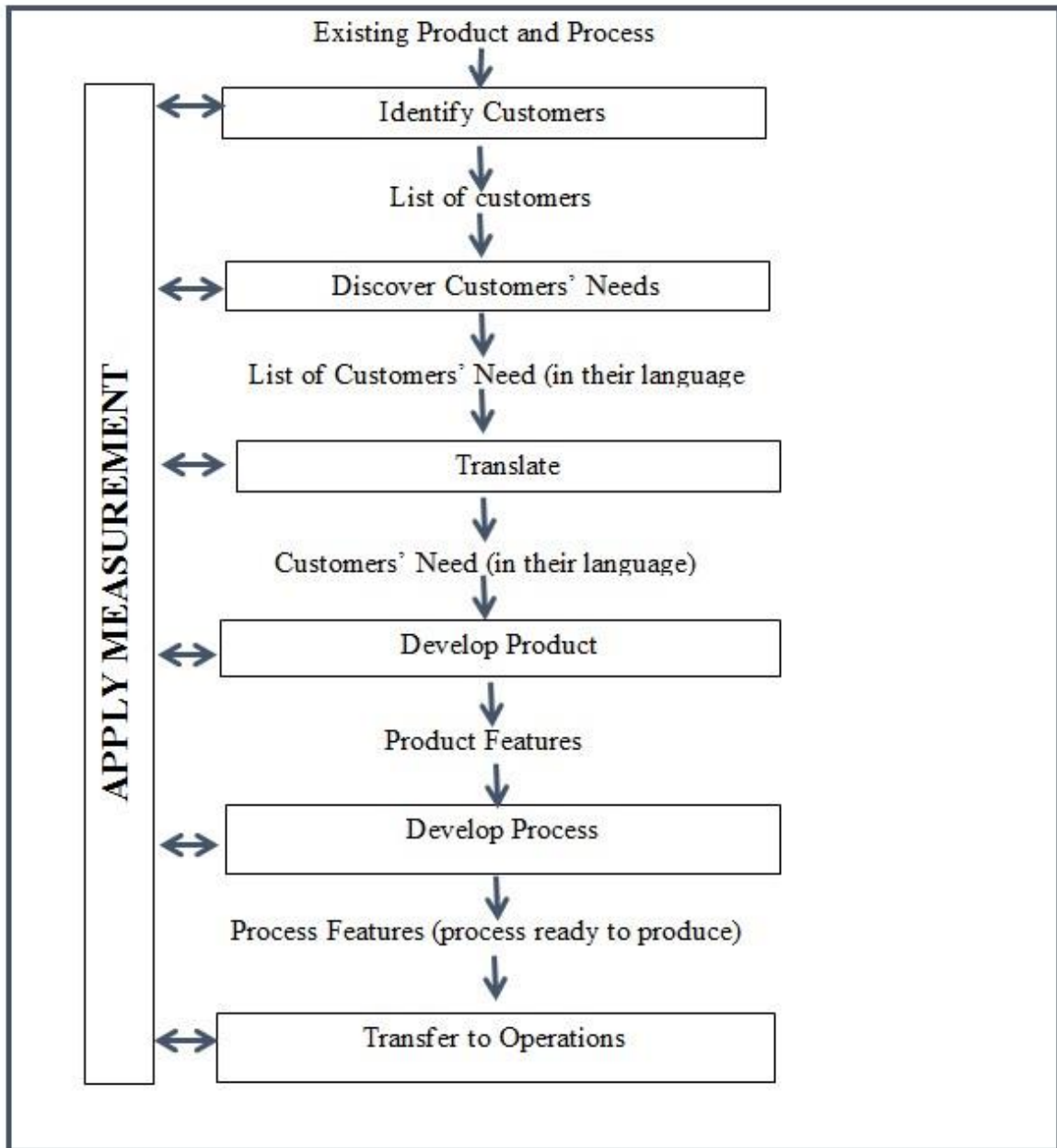

Fig.2.3: Road-Map for Generalized Quality Planning Process (Juran, 1989)

Quality planning is therefore concerned with the organization's goals, product features as well as processes. It has been mentioned above that all levels within the organization should participate in quality planning. Suppliers and customers are also expected to participate somehow in the planning. For example, customers can participate effectively in identifying client needs and factors of customer satisfaction.

The quality-planning route should end with simple specific tasks and directions for operating workforces to satisfy particular definite customer needs. The plan should identify the processes for transforming customer needs into product specifications. These processes should be established carefully focusing on meeting the following goals of a product:

- meeting customer needs
- meeting specifications
- most economical

In a nutshell, the processes must assure a quality product.

2.7.4 Quality Control

Quality control is a fundamental part of quality management, it is a managerial process conducted throughout the organization to achieve organization's objectives. Juran (1989) defines control as a managerial process during which we:

- Evaluate actual performance
- Compare actual performance to goals
- Take action on the difference

Similarly, another methodology for conducting control is known as PDCA Control Cycle. The PDCA Control Cycle is shown in the diagram (Fig. 2.4)

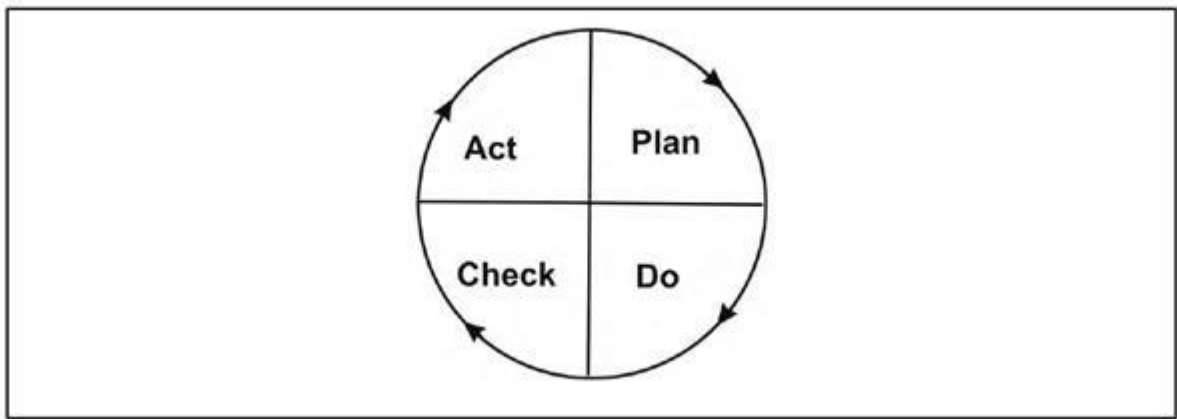

Fig. 2.4: PDCA Control Cycle (Ozeki and Asaka, 1990)

PDCA Control Cycle as shown in the diagram (Fig.2.4), according to Ozeki and Asaka (1990:7), consists of:

- Plan: Determine your goals and develop a process for achieving these goals
- Do: Implement your plan
- Check: Evaluate the results of your plan and its implementation □ Action: Take the necessary action constituting quality control.

More details on quality control are discussed in the sections that follows

2.7.5 Quality Improvement

Quality improvement acts as wheels on which the whole organization is driven forwards.

Basically, quality improvement is a necessity for the organization's management because of the following reasons:

- To survive in the competitive environment
- To catch up with rising customer satisfaction levels

- To keep abreast with continuously changing quality criteria
- To overcome the shortcomings of new technology

With improvement is implied the „organized creation of beneficial change; the attainment of unprecedented level of performance“ (Juran, 1989). It therefore follows that quality improvement is a beneficial change in the organization“s objectives, structure, process and product to increase performance as well as to eliminate deficiencies.

Improvement may be either small yet constant steps of progress or one drastic step taken periodically. The former is termed Kaizen (Japanese for „small improvements“) and the latter Kairyo (Japanese for „one great improvement“). The diagram (Fig. 2.5.) depicts these two concepts, which constitute quality improvement.

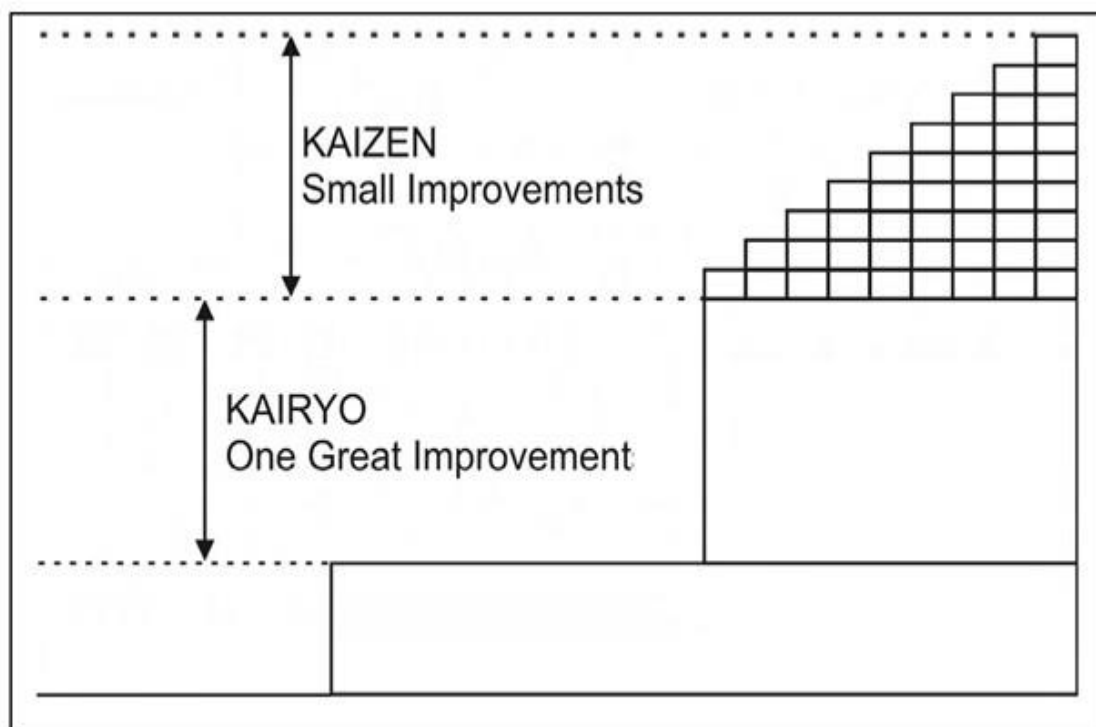

Fig. 2.5: Kaizen and Kairyo Improvements (Galgano, 1994)

Kaizen improvement is a systematic approach directed at organization's routine processes and could be conducted by everyone. On the other hand, Kairyo is conducted mainly by adopting improvements on a project-by-project basis and usually, it is undertaken by a specific group of people expected to produce a breakthrough result (Galgano, 1994).

Both of these kinds of improvements can take the form of a specific improvement strategy.

Kinlaw (1992) suggests five different improvement strategies. They are listed hereunder:

- Responding to an immediate problem.
- Preventing the occurrence or recurrence of a problem
- Upgrading machines, methods and techniques
- Experimenting to improve an operation or work process
- Creating a new opportunity to anticipate the developing needs of a customer

2.7.6 Quality Standards

The term „standards“ as it is used in this context implies documented agreements containing technical specifications or other precise criteria to be used consistently as rules, guidelines or definitions of characteristics, to ensure that materials, products, processes and services are fit for their purpose (ISO, 2002).

From the 1950s, many organizations developed quality standards that suit their own businesses since their activities were restricted, mainly, to the local economy. By the 1970s, the expansion of an organization's activities at national level, resulted in replacing many firm-specific standards by national standards. However, in the 1990s, international competition and the globalized marketplace made it imperative for international standards to play a role to facilitate international trade and to unify the international quality language

particularly for the international contractual agreements (Peach, 1997). In the next section, an overview of one quality standard is presented.

2.7.7 ISO 9000

The International Organization for Standards (ISO) is a worldwide federation of one national standard body from each one of the more than 140 member countries. ISO 9000 is one of a series of the ISO standards. ISO 9000 series of standards was first issued in 1987 and it qualifies organizations' quality management system and it comprises of two basic kinds of standards (Peach, 1997), which are:

- Product standards (quality assurance)
- Quality system (management system)

However, ISO 9000: 2000 family consists of four primary standards (ISO, 2002), namely:

- ISO 9000: Quality management system; fundamentals and vocabulary
- ISO 9001: Quality management system requirements that demonstrate its capability to meet customer requirements and enhance customer satisfaction
- ISO 9004: Quality management systems; guidance for performance improvement to enhance satisfaction for interested parties
- ISO 19011: Guidelines on quality and/or environmental management systems auditing.

In 1987, the International Organization for Standardization released the ISO 9000 quality standard series. The ISO quality standards are a series of internationally accepted guidelines as to how companies should set-up quality assurance systems (Kantha, 2004). The standards are designed to guarantee a consistent level of quality of products and services provided by

companies through the use of procedures, controls, and documentation, to identify mistakes and streamline its operations.

The ISO quality management system is generic in nature and applicable to all companies, regardless of the type and size of the business, including small and medium enterprises (SMEs) (Sroufe and Curkovic, 2008; Kartha, 2004) and is being used by many organizations as a stepping-stone to TQM (Conca et al., 2003; Zhang, 2000; Kartha, 2004; Escanciano et al., 2001; Hiyassat, 2000). The original ISO quality standards underwent a major revision in 1994 and 2000 (Sroufe and Curkovic, 2008).

2.8 QUALITY CONTROL AND QUALITY ASSURANCE

Quality assurance is based on the principle of quality first, and it is part of the broad concept of quality control. Fig. 2.6 shows that quality assurance is within and at the core of the quality control area. Quality assurance is concerned mainly with product quality and customer satisfaction. At the end of the day, the customer needs a quality product and not, for instance, quality documentation.

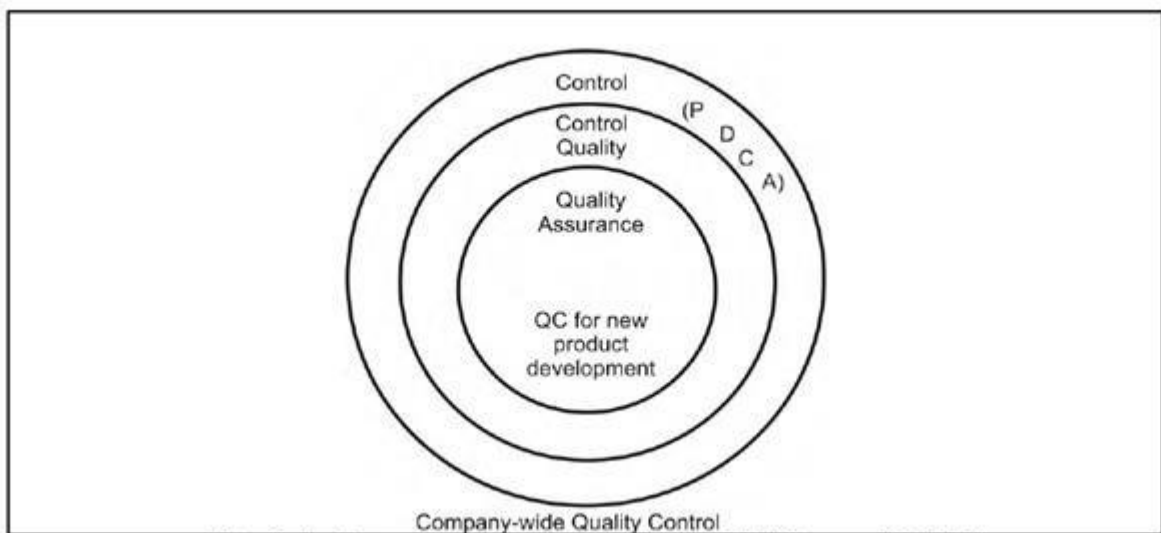

Figure 2.6 Company-wide Quality Control

(Ishikawa, 1985)

Ishikawa (1985) presents the diagram shown in Fig.2.6 illustrates the assurance of quality in a product so that a customer can buy with confidence and use it for a relatively long period of time with confidence and satisfaction. Not far from this view, ISO 8402 defines quality assurance as “all the planned and systematic activities implemented within the quality system and demonstrated as needed to provide adequate confidence that an entity will fulfil requirements for quality” (Peach, 1997). Moreover, the Japanese Industrial Standard JIS Z8101 of 1981 defines quality assurance as an activity “undertaken by manufacturers” and the definition mentions the same objective of carrying out assurance activities that are to satisfy the requirements of the customer (Ozeki and Asaka, 1990).

2.8.1 Quality Control System Objective

While keeping the broad meaning of quality in mind, a quality control system is the work structure that contains, organizes and directs all quality control activities so as to achieve quality product and customer satisfaction. Control, in this context, refers to “the broad administrative and technical area of developing, maintaining and improving product and service quality” (Feigenbaum, 1983). In fact, the scope of a quality control system must be widened like that because quality cannot be expected or inspected into the product. But quality must be designed and built into it throughout the organization’s activities including market research, inspection of incoming materials, administrative work and the training system (Feigenbaum, 1983). On the other hand, the objectives of a quality control system within the organization are:

- Carrying out plans and improvement program
- Developing plans of daily routine work
- Comparing results against quality objectives
- Acting on the difference between actual performance and quality objectives

Two broad objectives of quality control system are:

- All organizational activities can be grouped into processes; the output of each process forms part of inputs of the next process and the person(s) who receive process output is a customer for the preceding process. In this case, quality control system ensures that all arrangements achieve a quality output that is most satisfactory for its intended customer.
- Cost control for activities and process

2.8.2 Quality Control System Organization

The objective of the system mentioned previously is quite broad, since the quality control system forms the heart of the organization, ensuring its survival and progress. Therefore, a well-integrated system should be set up with developing clear performance measurements and establishing infrastructure. The quality control system covers all management and workforce levels, since quality is the job of everyone in the organization and each person is responsible for the quality of his or her own work (Galgano, 1994), entails providing top management, supervisors as well as workforce with training to enable them to carry out control activities and use control tools. In fact, the quality control system is an integral part of business management, and not separate from it. However, some structures such as a quality council at top management level and a „quality circle“ at workforce level may be established to pay particular attention to the quality programme. A quality supervisor maybe needed to coordinate quality activities throughout the organization and outside. In addition, more responsibility is given to management and engineering to provide the organization with leadership in order to assure quality and quality cost (Feigenbaum, 1983). The important factor in quality control organization is to consider that quality is a mandate of each and every person. As such, authority relevant to each person's position and responsibility should be

given. Naturally, this implies providing individuals with adequate training and establishing a motivational and recognition system.

2.8.3 Aspects to be controlled

Quality control is a fairly broad concept. It basically comprises all that affects the wide meaning of the quality concept. Therefore, any attempt to gather and group all aspects that should be controlled may end up with excluding some important aspects. However, the following categories of aspects to be controlled are believed to be fairly comprehensive. These categories are: activities, management of organization as a whole (Galgano, 1994), and technology (Feigenbaum, 1983). They are briefly discussed below: **a) Activities**

Activities that can be controlled are divided into two groups. See diagram (Fig. 2.7):

- Activities directly connected with a product in different fields such as activities of marketing and market research, engineering, manufacturing, purchasing, supervision, installation and resource utilization.
- Activities not directly connected with a product such as the information system and documentation, budgeting, investment planning, marketing planning and planning for resource utilization. However, all plans are developed, in this category, starting with potential problems involved, where the root cause of those problems are identified and eliminated. Subsequently, a new plan is developed and implemented.

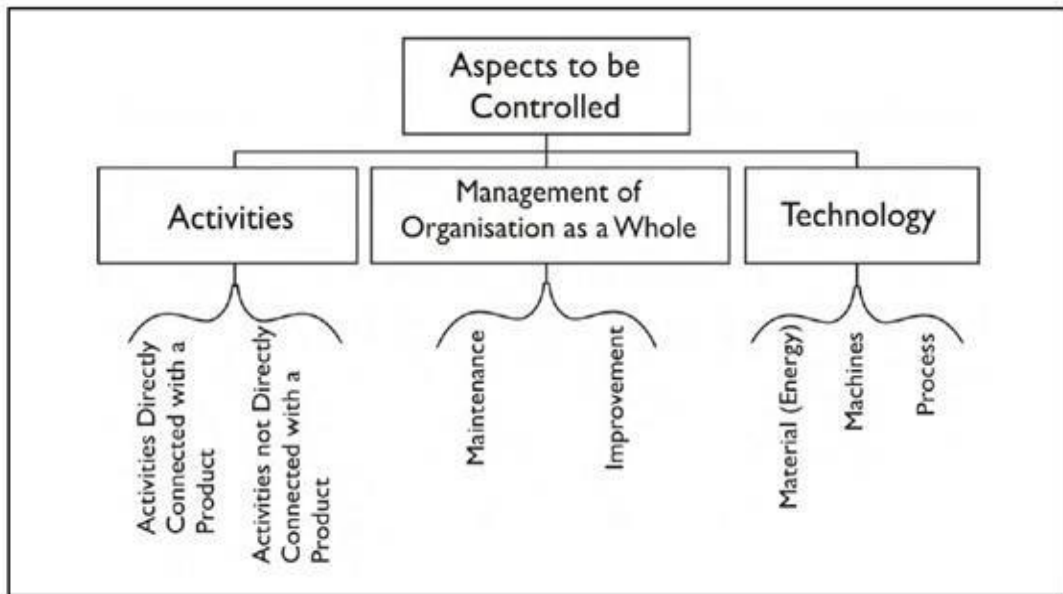

Figure 2.7 Aspect to be controlled

b) The Management of the Organization as a Whole

It is management's responsibility to provide the organization with strategy and policies to provide people with leadership so as to make optimal use of human capabilities. Nevertheless, management should look at two broad organizational problems; problems of today that prevent organizations from maintaining quality levels, and problems of the future which affect organization's continuity and competitive position (Deming, 1982). Therefore, management activities concerning quality control at organizational level are: maintenance and improvement.

Maintenance: To maintain the level of performance achieved in daily routine work.

Galgano (1994) suggests three fundamental conditions to maintain the level of performance:

- Maintaining minimal variations within process parameters
- Doing things right the first time.

- Delegating managerial activities and increasing employee involvement.

Improvement: Improvement, mainly, is a management responsibility. Two approaches can be adopted in order to carry out the improvement activity:

- Small-step improvements by going around the PDCA cycle repeatedly. See diagram (Fig. 2.8).
- One big-step periodic improvement. It may sometimes be called innovation or breakthrough.

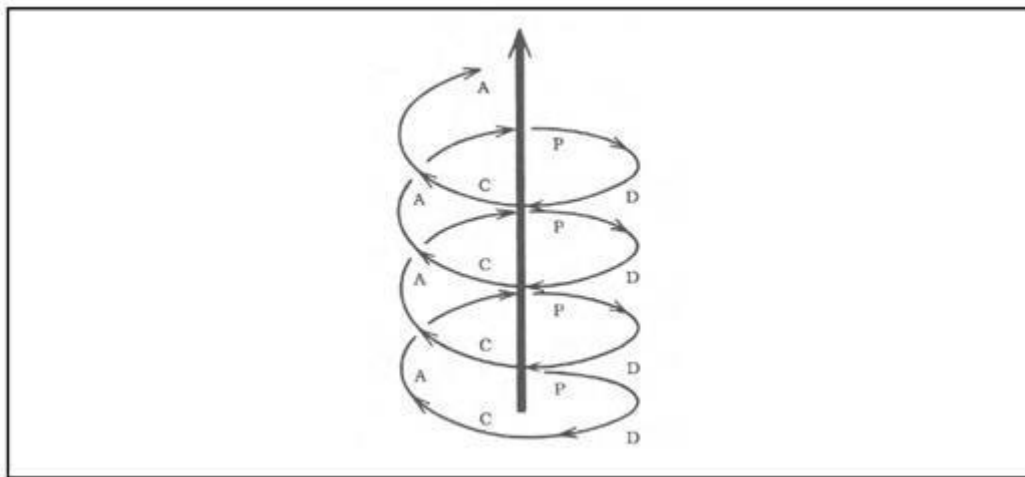

Fig. 2.8 Repeated Application of the PDCA Control Cycle (Ozeiki and Asaka 1990)

c) Technology

Technology has an increasing impact on business trends and, in part, also on the quality control system. Technology in this context comprises material and energy, machinery and processes (Feigenbaum, 1983). Material characteristics determine how it should be manufactured and controlled. On the other hand, machines and tools are of direct impact on quality production as well as level of accuracy and inspection. Computers and softwares have

a major impact on documentation systems and facilitate implementation of statistical quality control. Lastly, the whole business work may be broken down into processes in order to accomplish the organization's final goal. However, developing effective and efficient processes is crucial for quality control system's success. More elaboration will be provided on how to control process in the section that follows.

While developing a quality control system, management should realize two things that are of extreme importance:

- Management members alone cannot implement quality control system, therefore, management should involve all individuals and delegate control activities to each person within the organization as well as suppliers.
- Control should be directed towards results as well as the cause in order to influence the result, and since there are many causal factors that can affect quality, it is management's role to identify the most important one(s), which considerably influence results. Management should then standardize how causal factors can be easily controlled (Ishikawa, 1985).

2.8.4 Process Control

Tanya Vinos (2002) reports in an article entitled "Process is King" the success story of Honeywell's (an electromechanical firm) plant in Warren where it once had row-upon-row of hand assembly tables with 200 production employees. Today, the plant has only 80 production employees operating seven automated interchangeable lines. The growth in output per employee from 1997 to 2001 has been 69 percent. This has been coupled by a marked reduction of customer rejection rate range from 250-500 ppm per year to 3 ppm per year in 2001 and currently down to 0 ppm. Cynthia M Knautz, a manufacturing engineer with

Honeywell at Warren, according to Vinos, attributes this achievement to the implementation of quality process control techniques. So, what is process and how can process control be implemented?

2.8.5 Defining a Process

A Process is a series of activities connected to each other functionally, in order to accomplish particular objective(s). Clause 3.4.1 of ISO 9000-2000 defines „process“ as a set of interrelated or interacting activities which transform inputs into outputs: Note 1: Inputs to a process are generally outputs of other processes. Note 2: Processes in an organization are generally planned and carried out under controlled conditions in order to add value (ISO 2001).

A process is basically a set of activities that could be manufacturing work, engineering or administrative activities. In fact, the new trend of management tends to accomplish the whole organisation work by means of a process. ISO 9000:2000 (ISO: 2001), for instance, as mentioned above, adopts process as an approach to quality management system. Moreover, Lawton (1993) considers that managing business, as a process to achieve quality is one of the significant changes now sweeping American business.

The rationale of grouping the whole business activities into series of processes is that:

- It is difficult to control a relatively large number of activities throughout the organization in different fields and functions yet the task is much easier when grouping activities into a limited number of processes, especially, when identifying the most influential factor(s) affecting quality of process output.
- It is difficult to integrate all scattered activities so as to achieve specific quality goals

However, in process approach case, all processes which comprise of the entire organization's work can be designed and linked to each other in such a way that to achieve specific quality goal(s), which in turn can be deployed down to form the target objective of each process output (Galgano, 1994).

- The last and maybe the most important reason is that, processes form the steps of achieving a product. In order to control an operation, its process must be controlled but not its product. However, only the product of an operation can be inspected. Similarly, the quality process should be controlled so as to achieve a quality product. Therefore, management's focus should be diverted towards processes and causes in addition to the focus on outputs and effects (Galgano, 1994).

Before discussing process control, process context as well as quality process requirements need be clearly stated. These two concepts are briefly presented hereunder:

2.8.6 Process Context

Process context includes the following aspects (See diagram Fig. 2.9):

- Input: which includes the output of the preceding process
- Resources: In the case of manufacturing, process resources may consist of materials, machines, employees, and information. Information specifies the way how the process is carried out.
- Process: Sometimes called cause(s), is a mechanism for transforming inputs into outputs using assigned resources.
- Output: Also called effect or product, (Juran, 1992), is the result of process.

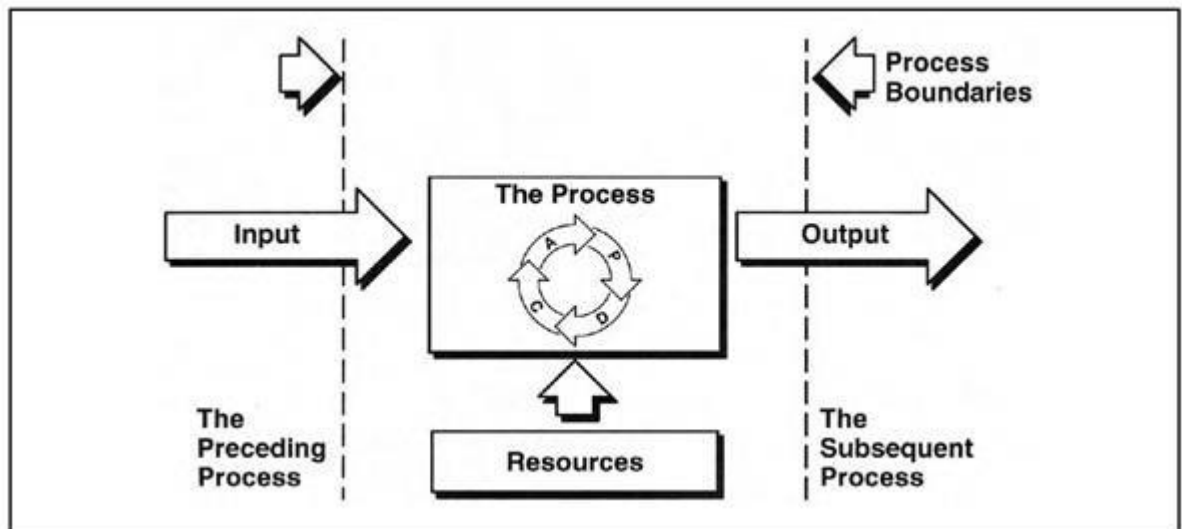

Fig. 2.9 Process Context (Jablonski, 1994:)

2.8.7 Quality Process Requirements

A process is designed in a way so as to achieve particular product(s). It is normally the case that process and product features are correlated. Hence, the need of having quality product must be reflected in the process features. Nevertheless, the following are requirements for achieving quality process.

- Effectiveness: the effectiveness of a process implies its ability to achieve desired results (ISO:2000), with respect to the process's effectiveness level based on the extent to which the process is satisfactory as an input for the process that follows it (Galgano, 1994).
- Efficiency: efficiency itself will be evaluated according to what has been achieved compared to resources used (ISO 2000).
- Reliable: achieved when the percentage of obtaining desired results (via this process) is consistent and relatively high over time.

- **Stable:** Process factors are the aspects within the process, which influence the process output quality. Process quality is basically the quality characteristics of the product. Now, stability is attributable to process if it produces quality characteristics that are predictable, consistent and within the control limits.
- **Clear, easy, and smooth:** the relationship between a process and the preceding one and the one that follows should be clear. There should be no gaps between processes and between activities in a process. Otherwise, a potential mistake will occur. Process must be understandable for those people who are responsible for it, since they are the ones who should control it in the first place (Ozekia and Asaka, 1990).
- **Predictable:** process input and resources comprise production „condition“ or „causes“ which, intern, interact with each other to produce, on the other side, the output or „results“. So, the way and degree how „causes“ influence „results“ should be known in order to be able to control process.
- **Controllable:** this issue needs to be the first one, nevertheless, the process has factor(s) that affect its product quality, each factor affects quality to a certain degree; consequently, the design of the process should allow the person(s) that controls it to measure the effect of each factor, separately, on product quality.
- **The Feedback Loop:** the process must have a „feedback loop“ which allows controller to compare measurement against quality standards and customer requirements and then, in turn, to adjust and improve the process accordingly (Juran, 1992).

2.8.8 Quality Process Control

Process as an organizational unit is to be controlled. Control activities throughout the organization are carried out by the systematic approach of going around the Plan, Do, Check, Act (PDCA)

control cycle. Similarly, process, in essence, is controlled in that systematic way. However, the process needs to be further analyzed to know exactly how the PDCA cycle can be applied. Process, operationally, comprises three basic concepts, they are: essential variables, sources of disturbance, and the regulator (Galgano, 1994).

- Essential variables are those aspects that are attributable to quality requirements and, in part, related to either process itself or related to the output. Essential variables related to the process are typically, effectiveness, reliability, accuracy, turn-around- time (TAT) and resource utilization. On the other hand, essential variables related to output are, basically, the product features such as: dimensions, strength, and appearance.
- Sources of disturbance are those aspects that cause undesirable variations in the essential variables such as: tools accuracy, waste, lack of (skills, information), undesirable environmental conditions.
- The regulator contains those elements that keep the process running properly. Thus management sets up a process regulator for the consideration of quality process requirements in order to keep essential variables within quality requirement limits.

However, to fully control the process, the three process basic concepts should be controlled keeping in mind that the process regulator plays the essential role of controlling process (Galgano, 1994). Essential variables are the logical results of regulator, but still essential variables should be separately controlled. Juran (1992) suggests controlling variables by the means of:

- Inspection and test
- Evaluating control methods which were set up by regulator
- Data analysis and interpretation, this area of control is called Statistical Process Control (SPC)

Regarding sources of disturbance, the strategy of quality control is to investigate the cause of problem upstream and to prevent occurrence right there. Investigating the cause of the problem is known as Root Cause Analysis (RCA). For this purpose, Ishikawa (1985) suggests the use of a cause-and-affect diagram (see section 2.10.5). Generally, risk management and past experience are commonly useful means in order to discover and avoid potential source of disturbance.

Controlling the regulators, essential variables and source of disturbance is conducted through the implementation of the PDCA cycle. However, the PDCA cycle may be used as a problem preventing tool as well as a problem-solving tool. Galgano (1994) breaks down the PDCA cycle in terms of its use as a problem-solving tool into seven stages, namely:

- Identifying the problem [problem]
- Understanding the characteristics of the problem [observation]
- Searching for its cause [analysis]
- Eliminating the cause [action]
- Validating the effectiveness of the action [checking]
- Making the elimination of the cause permanent [standardization]
- Reviewing the activities and plan for future work [conclusion]

Two more points are essential while carrying out the process control activity and they are:

- The implementation of PDCA control cycle is continuous and essentially similar, to the use of the feedback loop.
- The relationship between process variables and product features should be known, however, one variable, often, is more important than the others that variable which is called the dominant variable must receive top priority to be controlled (Juran: 1992).

2.9 TOOLS AND TECHNIQUES FOR QUALITY CONTROL

In the era of competitive markets and globalization, quality concepts and philosophies have emerged as strategic issues at all organizational levels and in all industries. International quality standards and excellence models such the ISO 9000 standards, the EFQM model, formally known as European Foundation for Quality Management, Deming Prize and the King Abdul-Aziz Quality Award model require organizations' quality systems to be built on processes, rather than requirements, departments or functions. Consequently, proper process identification and management are becoming more relevant and critical challenges for quality professionals, process engineers and business leaders. World class organizations use total quality management (TQM) tools to identify, analyze and assess qualitative and quantitative data that are relevant to their processes with the main objective towards the continuous improvement of the process and the delivery of high quality products and services. Japanese quality guru, engineering professor, Kaoru Ishikawa who is the inventor of the seven basic quality tools stated clearly that 95% of quality related problems in any organization can be resolved using these tools and hence many opportunities for improving processes can be generated.

The seven basic quality tools have been used by quality professionals to identify procedures, ideas, statistics, cause and effect concerns and other issues relevant to their organizations. They can be used to enhance the effectiveness, efficiency, standardization and overall quality of procedures, products, services and work environment, in accordance with ISO

9000 standards. These tools and techniques have been used in manufacturing and services organizations to aid in the analysis, documentation and organization of quality systems.

They have also been used as problem solving and process improvement *tools* (Dias and Saraiva, 2004).

2.9.1 The seven basic quality control tools

The seven basic quality control tools are simple statistical tools used for problem solving and are considered as the most important tools that are able to solve up to 95% of problems. These tools are referred to as basic due to their suitability for use by even people with little formal training in statistics and the fact that they can be used to solve the vast majority of quality-related issues (Ishikawa, 1985). The basic tools make quality improvement and monitoring activities, and giving feedback to quality improvement team much easier (Rao et al., 1996). The suitability of the basic quality tools to aid and support problem solving is generally accepted.

Quality control activities are carried out by conducting the systematic approach of the Plan, Do, Check and Act (PDCA) cycle. The planning step begins with either an existence of a problem involved or preventing a problem from happening in the first place. Consequently, quality control activities start with the evaluation of actual performance. Therefore, accurate information is needed to establish factual-based decisions. Zairi (1991) suggests the following steps for gathering such information:

- Measuring with manufacturing
- Recording of measurement
- Analyzing the record and
- Using the analysis for feedback and corrective action

However, in practice, tools are needed to implement the above-mentioned steps. For this purpose, Ishikawa (1985) suggests the „seven quality control tools“ which according to Montgomery (1991), are also called the „magnificent seven“ to be used by everyone in the organization. These basic rules owe their origin to Kaoru Ishikawa. These seven quality control tools are extremely powerful and, as Ishikawa states, are able to resolve the great majority of problems in companies (Galgano, 1994). However, the outcomes of these tools are basically information that needs to be taken into account while improving process. When having such information,

the tool that maybe used to consider these outcomes is a systematic approach called the feedback loop. Juran (1989) established the feedback loop, (see Fig. 2.10 below) which consist of the following basic elements:

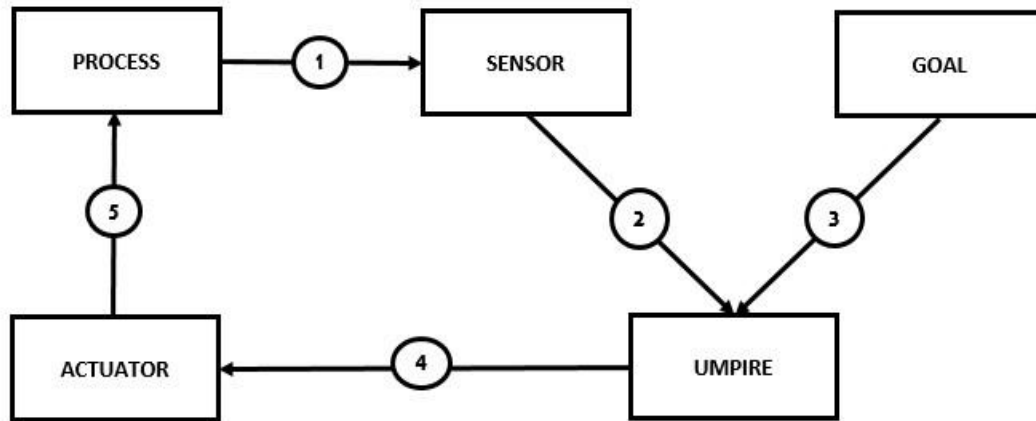

Fig. 2.10.: Feedback Loop

(Juran, 1989)

- The sensor: which follows and evaluates process outcomes.
- An umpire: who receives information about performances from sensor then compares it against standards and goals, the result of the comparison is the identification of differences between performance and goals.
- Actuator: making the changes needed on performance to conform to goals.

It is worthwhile to mention here that going through the feedback loop while conducting control activities is essential. These seven basic tools are briefly discussed in the following sections;

2.9.2 Check sheet

It is a form or document used to collect data in real time at the location where the data is generated. This captured data can be quantitative or qualitative (Schultz, 2006). When a process has been identified as a candidate for improvement, it is important to know what types

of defects occur in its outputs and their relative frequencies. This information serves as a guide for investigating and removing the sources of defects, starting with the most frequently occurring (Ishikawa, 1986). Ishikawa (1986) identified five uses for check sheets in quality control;

- To check the shape of the probability distribution of a process
- To quantify defects by type
- To quantify defects by location
- To quantify defects by cause
- To keep track of the completion of steps in a multistep procedure (in other words, as a checklist)

Category	Repetition	Frequency	Cumulative Frequency	Percentage	Cumulative percent
Tensile strength		28	28	72%	72%
Yield Strength		5	33	85%	85%
Elongation Percent		3	36	92%	92%
Effective diameter		2	38	97%	97%
Effective Weight		1	39	100%	100%

Fig 2.11. A typical Check Sheet for various steel tests

(Fouad and Mukattash, 2010)

2.9.3 Control Chart

This is a process behavior chart and in statistical process control, it is a tool used to determine if a manufacturing or business process is in a state of statistical control. If analysis of the control chart indicates that the process is currently under control (i.e., is stable, with variation

only coming from sources common to the process), then no corrections or changes to process control parameters are needed or desired. In addition, data from the process can be used to predict the future performance of the process. If the chart indicates that the monitored process is not in control, analysis of the chart can help determine the sources of variation, as this will result in degraded process performance (William, 2006). According to Poots & Woodcock (2012), control charts are typically used for time-series data, though they can be used for data that have logical comparability (i.e. you want to compare samples that were taken all at the same time, or the performance of different individuals), however, the type of chart used to do this requires consideration.

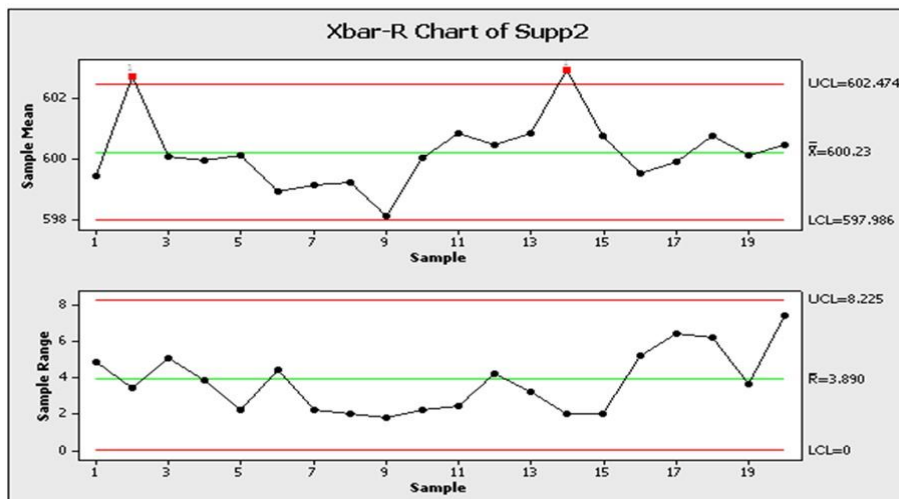

Fig. 2.12 A Typical Control hart (Montgomery, 1991)

2.9.4 Histogram

Before taking steps to improve processes, data is often collected to see how processes are doing at the present time. One way to describe and evaluate performance is to display this data in a chart called a “histogram”. A histogram is a pictorial representation of a set of data. It is created by grouping the measurements into cells. Histograms are used to determine the shape of a data set. Also, a histogram displays the numbers in a way that makes it easy to

see the dispersion and central tendency and to compare the distribution to requirements. There are numerous situations where histograms can be used to show how much variation exists in process. Histograms can be valuable troubleshooting aids. Comparisons between histograms from different machines, operators, vendors, etc., often reveal important differences.

A histogram is a picture of the data distribution that includes its spread and shape. This can provide clues about the variation that exists in the work performed. Distributions can be skewed in either a positive (tail of the distribution to the right) or negative (tail of the distribution to the left) direction from the center. By examining the spread and shape of a distribution, the extent of variation in a work process can be determined. This can provoke further discussions to identify the cause of variation and the measures needed to either control or reduce it. A foundation of continuous improvement effort is data collection. Data are used to better understand variation in a process and determine how well are relevant standards met. A histogram is a useful tool to display these findings in order to identify current performance and show how processes are improved over time (Paliska, Pavletić, Soković, 2008).

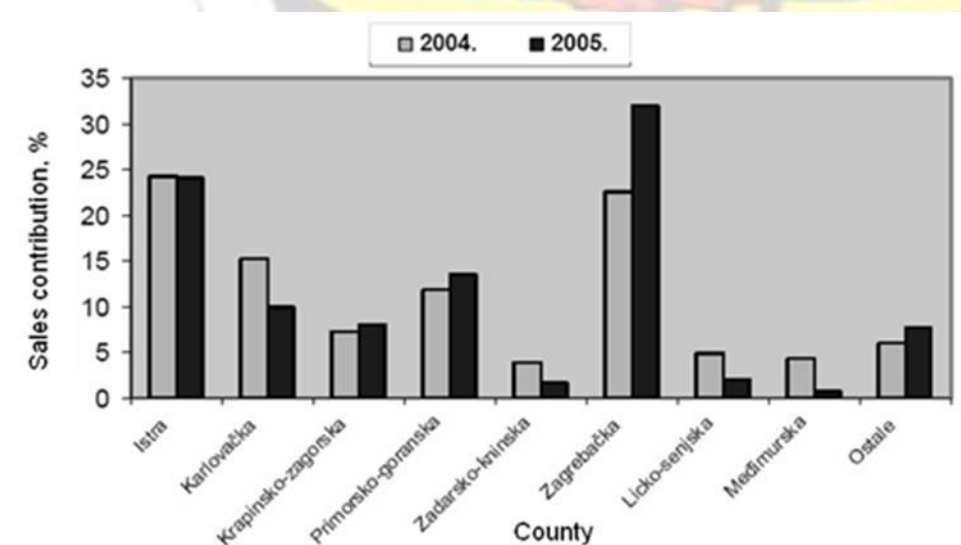

Fig 2.13 Atypical histogram

(Fouad and Mukattash, 2010)

2.9.5 Cause and effect diagram

This is a casual diagram that shows the causes of a specific event (Ishikawa, 1976). Common uses of the Ishikawa diagram are product design and quality defect prevention, to identify potential factors causing an overall effect. Each cause or reason for imperfection is a source of variation. Causes are usually grouped into major categories to identify these sources of variation. The categories typically include:

- People: Anyone involved with the process
- Methods: How the process is performed and the specific requirements for doing it, such as policies, procedures, rules, regulations and laws
- Machines: Any equipment, computers, tools, etc. required to accomplish the job
- Materials: Raw materials, parts, pens, paper, etc. used to produce the final product
- Measurements: Data generated from the process that are used to evaluate its quality
- Environment: The conditions, such as location, time, temperature, and culture in which the process operates

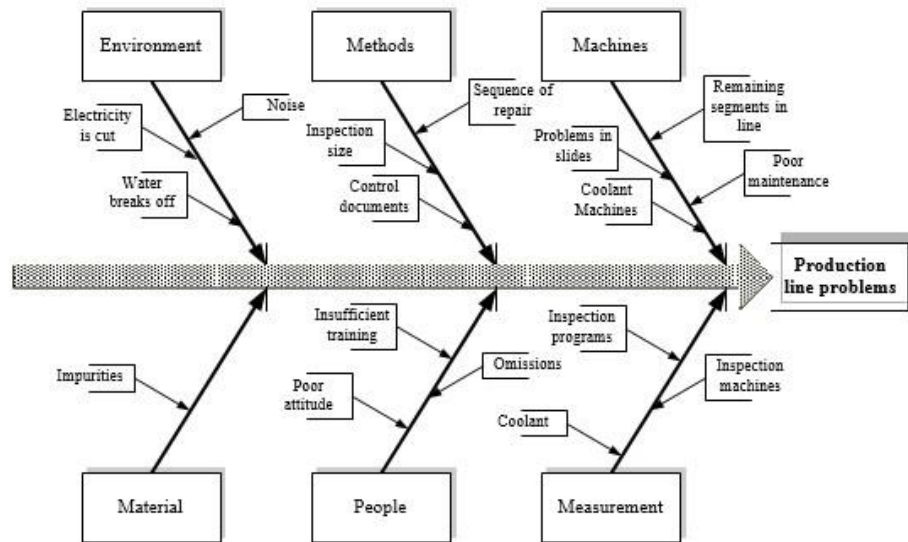

Fig. 2.14 Cause and Effect Diagram for analysis

(Fouad and Mukattash, 2010)

2.10.6 Pareto chart

This is a type of chart that contains both bars and line graph, where individual values are represented in descending order by bars, and the cumulative total is represented by the line. The purpose of the Pareto chart is to highlight the most important among a (typically large) set of factors. In quality control, it often represents the most common sources of defects, the highest occurring type of defect, or the most frequent reasons for customer complaints, and so on. The Pareto analysis is based on Pareto's "80-20" rule (Kolarik, 1995). According to Juran and Gryna (1988), 20 percent of cause's accounts for 80 percent of quality failures hence quality improvement can only be continued and achieved by solving problems no matter how little it may appear. This can be done by finding the main causes of problems. (Tang et al., 2005). The application of the Pareto analysis therefore cannot be over emphasized in the quest to achieve a quality in construction industry in Ghana.

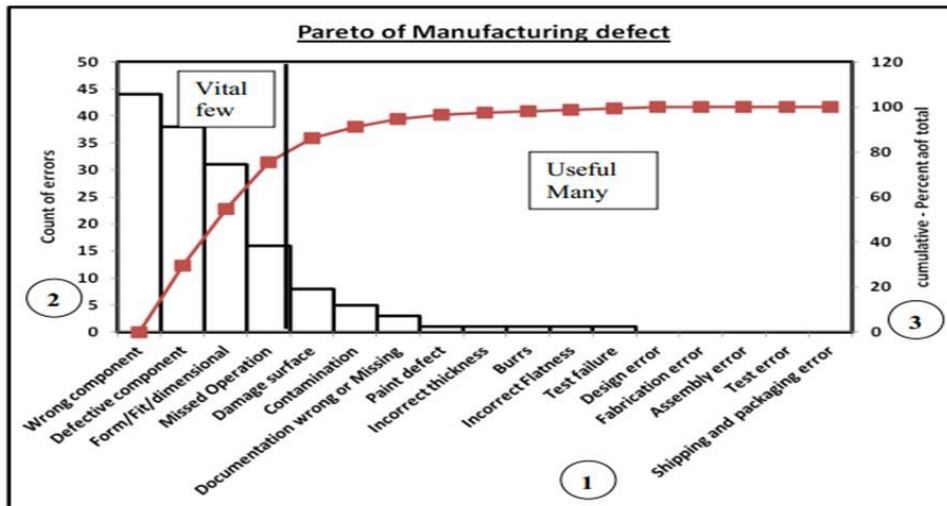

Fig.2.15 The Pareto diagram

(Galgano, 1994)

2.9.7 A scatter diagram

A scatter plot is used when a variable exists below the control of the experimenter. If a parameter exists that is systematically incremented and/or decremented by the other, it is called the independent variable and is customarily plotted along the horizontal axis. The measured or dependent variable is customarily plotted along the vertical axis. If no dependent variable exists, either type of variable can be plotted on either axis or a scatter plot will illustrate only the degree of correlation (not causation) between two variables. The cool scatter plot can suggest various kinds of correlations between variables with a certain confidence interval. For example, weight and height, weight would be on x axis and height would be on the y axis. Correlations may be positive (rising), negative (falling), or null (uncorrelated). If the pattern of dots slopes from lower left to upper right, it suggests a positive correlation between the variables being studied. If the pattern of dots slopes from upper left to

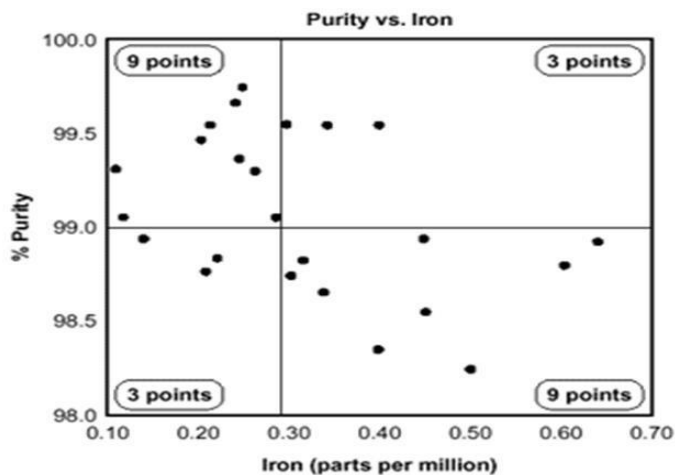

Fig. 2.16 Scatter Diagram, (Galgano, 1994)

lower right, it suggests a negative correlation. A line of best fit can be drawn in order to study the correlation between the variables. An equation for the correlation between the variables can be determined by established best-fit procedures. For a linear correlation, the best-fit procedure is known as linear regression and is guaranteed to generate a correct solution in a finite time. A scatter plot is also very useful when one wishes to see how two comparable data sets agree with each other. One of the most powerful aspects of a scatter plot, however, is its ability to show nonlinear relationships between variables. Furthermore, if the data are represented by a mixture model of simple relationships, these relationships will be visually evident as superimposed patterns (Tague, 2004).

2.9.8 Flowchart

A process flow chart is simply a tool that graphically shows the inputs, actions, and output of a given system. The purpose of flow chart is to help people to understand the process. A flow chart illustrates the activities performed and the flow of resources and information in a process. Two types of flow charts are particularly useful – high level and detailed. A high level flow chart illustrates how major groups of related activities, often called “sub processes”,

interact in a process. Typically, four to seven sub processes are shown in a flowchart. By including only basic information, high level flowcharts can readily show an entire process and its key sub processes. A detailed flow chart provides a wealth of information about activities at each step in a sub process. It shows the sequence of the work and includes most or all of the steps, including rework steps that may be needed to overcome problems in the process. A quality improvement team can increase the detail to show the individuals performing each activity or the time required to complete each activity. If necessary, the link between various points in the sub process and other high level flow charts of the process can also be shown. An organization pursuing quality improvement is constantly looking for ways to improve the effectiveness and efficiency of its work (Paliska, Pavletić, Soković, 2008).

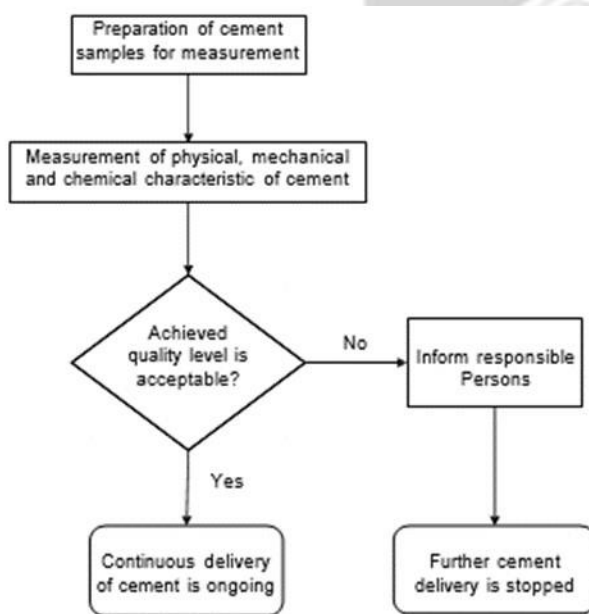

Fig.2.17 A typical flow chart of cement sampling and quality control (Paliska, Pavletić, Soković, 2008)

2.10 APPLICATION OF QUALITY TOOLS TO IMPROVE QUALITY

Quality remains a critical issue for the construction industry. While the cost of quality rectification problems is of the magnitude of 3.4 percent to 6.2 percent (Thomas et al., 2002), some of the researchers have put the cost of rework as high as 12 percent (Burati et al., 1992). Although there may be a disparity among the researchers in quantifying the magnitude of cost of quality rectification, all of them agree on the fact that there is an enormous amount of cost savings if the construction companies focuses on improving the quality of the construction service. Among some of the techniques and strategies to improve the quality related problems include identifying the causes, magnitude and cost of defects (Love, 2002; Josephson and Hammralund, 1999). These strategies aim to gather and analyze information at a fundamental level, in order to get to the root of the problem, by taking into account various perspectives such as type of defects, their frequency of occurrence, cost of rectification and their origin or cause (Karim et al., 2006). For very small companies the root cause of quality problems may be obvious but once we get beyond the very small business, most decision points and problem's root cause or the best-course decision will remain obscure until valid data are studied and analyzed. It is for these cases that quality management tools play an important role to improve the quality standards of the projects that the company undertakes.

Some of these tools very often used in the quality management system are Pareto chart, cause-and-effect diagrams, check sheets, histograms, scatter diagrams, run charts and control charts, stratification, flow charts etc. Although most of these tools originated in the manufacturing industries, they can be applied quite satisfactorily to construction processes as well when sufficient data is available. These quality tools enable today's employees, whether engineers, technologists, production workers, managers, or office staff, to do their jobs efficiently. When these tools are applied to problem solving or decision making, better solutions and decisions

are developed. The application of these tools begins only after understanding the company policy, managers and workers viewpoints, and challenges faced by the company.

Craft and Leake (2002) favor the use of simple data analysis tools such as Pareto chart in decision making. The Pareto chart is a very useful tool whenever one needs to separate the important from the trivial. Despite its simplicity, „Pareto Principle“ is quite powerful and has been used quite widely (Karim et al., 2006). When root cause of the problem is identified by using Pareto charts, „cause and effect diagram“, also known as fishbone diagram can then be used to identify and isolate causes of a problem. Such diagrams separate causes from symptoms and force the issue of data collection and can be used with any problem (Goetsch and Davis, 2006). Since they are not based on statistics, they do not demand a collection of large data samples as required by other quality tools.

2.11 ADVANTAGES IN THE APPLICATION OF QUALITY CONTROL TOOLS

Literature has it that, implementation of quality control measures can be a solution for the problems (that is costs, productivity, occupational safety and health) that the construction industry is facing (Kuprenas & Kenney, 1998; McKim & Kiani, 1995; Schriener et al., 1995). It has been proven that implementation of quality control in the construction industry speed-up projects and also increases profitability (Chase, 1998).

According to literature, implementation of quality control measures prevents defects and accidents before they happen, saving the company millions of dollars (Formoso & Revelo, 1999; Lahndt, 1999; Soares & Anderson, 1997). Rework and its associated huge cost can be completely avoided through the implementation of quality control measures (Love et al., 1999). Higher customer satisfaction, improved schedule performance, improved relationships with architect/engineering are the results of quality control implementation (McIntyre and Kirschenman, 2000).

2.12 QUALITY CONTROL (QC) IN PRECAST CONCRETE PRODUCTION

Quality control measures precast products' characteristics and ensures they bear on the ability to satisfy the client's needs and requirements (Warsza-wiski, 1999). The quality level can be measured in terms of performance in health and safety, serviceability, aesthetic, etc. Usually the client's requirements are stated clearly in method statements in the contract specifications. The objective of a QA/QC system is to maximize predictability and consistency of quality of precast components so as to ensure they are up to a required standard. There are some guidelines in codes and standards for users, designers and producers to determine their desired level of quality. These include direct performance, aesthetic, technological and economic considerations. The impact of possible cracks, deflections, and size deviations on the strength, durability, serviceability, and maintainability of the components are covered in the first consideration. The various defects and blemish that will affect the building's appearance is included in the second consideration. The precision levels that can be expected from the equipment for batching, moulding and other production operations are covered in the third consideration. The last consist of the cost of equipment, materials, skilled labor, and inspection. While manufacturing precast components, a full record of concrete mix proportions, appearance and consistency of the mix results, as well as other pertinent factors like ambient temperature, humidity and timing of operation including mixing, handling, placing and curing should be maintained (Richardson, 1991). Before concreting, concrete covers and location of reinforcements must also be doublechecked. A well- maintained supply of moisture promotes cement paste hydration, which can reduce concrete permeability and improve its performance especially in weathering characteristics. The inspection of finished precast elements should be carried out before their storage and delivery to the installation site. Work should be carried out by personnel other than those responsible for production. Quality control staff oversees „the production process“, „carrying out

inspections“, „checking the moulds, steel and concrete“, „sampling materials“, as well as „testing specimens“. Periodic audits and system reviews are important in maintaining the quality system.

2.13 CONCLUSION

Quality control is a system that contains, mainly, the components of Plan-Do-Check-Act (PDCA) cycle. Quality control is basically prevention and its objectives are to carry out organisations plans and to check result against quality objectives. If variations are found, corrective action has to be taken accordingly, and that implies developing new plans for improvement. Ultimately, quality control objective is achieved when customer is fully satisfied.

Quality control is conducted throughout the organization and it forms an essential part of both managerial activities of quality planning and quality improvement. In fact quality control system is an integral part of business plan. In effect, quality control system organisation may not have a separate structure. However, some structures such as quality assurance department and quality council may be established to pay particular attention to critical quality activities. It remains, however, the responsibility of every person within the organization to ensure quality in his/her function on the job.

Activities are better controlled when grouped into sets of processes. While realizing that, quality product is just a result of quality process. Therefore, process should possess specific requirements in order to be able to deliver its intended product.

Nevertheless, the first step in the control process is to design it in such a way that it is capable.

In addition, the relevant quality factors (process variables) as well as, causes that might disturb process flow should be controlled. Quality control starts with a step of planning which in turn

is based on data. The seven basic quality control tools are powerful tools in order to organize, clearly display, and analyse data. This facilitates the controller's role of evaluating the actual performance. Information resulting from the use of the seven control tools goes through the feedback loop, which in turn, forms the bases to take relevant corrective action.

KNUST



CHAPTER THREE

RESEARCH METHODOLOGY

3.1 INTRODUCTION

This chapter discusses the research methodology adopted for this study. The Chapter addresses data collection instruments, methods, and procedures. It provides detailed explanations to each of the methods employed and how the methods adopted were used to address the aim and objectives. It explores the approaches implemented in order to bring to bear the core issues as pertaining to the level of knowledge and the usage of the seven basic quality control tools by producers of precast concrete products in Ghana.

3.2 RESEARCH STRATEGY, DESIGN AND PROCESS

Research strategy deals with how the research objectives are questioned. The three main strategies are quantitative, qualitative, and triangulation (Naoum, 1998). The decision to follow any particular strategy depends on the purpose of the study, the type and availability of information for the research (Naoum and Coles, 1997). However, research design deals with the framework for data collection and analysis; the structure that guides the execution of the technique for collection and analysis of data, which provides the connection between empirical data to its conclusions, in a logical sequence to the initial research question of the study (Bryman, 2004: 1992); and includes experimental, survey, action research, and case study (Baiden, 2006). Research process on the other hand addresses data collection instruments, methods, and procedures. It provides detailed explanations to each of the methods employed and how the methods adopted are used to address the aim, objectives and research questions.

This research follows a quantitative strategy and adopts survey questionnaire which is preceded by thorough literature review and interviews. A survey questionnaire is selected because of the need for generalization on the findings across the construction manufacturing industry. It also enhances the reliability of observations and improves replications because of the inherent standardized measurement and sampling procedures (Oppenheim, 2003).

3.3 POPULATION AND SAMPLING

3.3.1 The research population and sample

Collis and Hussey (2003), define a population as “any precisely defined set of people or collection of items which is under consideration”. Collis and Hussey (2003), define a sample as made up of the members of a population” (the target population), the latter referring to a body of people, or to any other collection of items, under consideration for the research purpose. For the purpose of this survey, the population is Precast Concrete Products Producing Companies operating in the Accra and Tema cities of Ghana

Accra and Tema which are the first urban agglomeration in Ghana formed the area for this study. The motivation in selecting Accra and Tema is based on the fact that they represent a large city in the Ghanaian context and so provide an opportunity to investigate the level of knowledge and usage of the seven basic quality control tools in the concrete manufacturing industry because of the number of such companies operating from there. Given that economic growth is largely skewed towards the capital, more than 60% of the registered construction companies tend to operate officially in the Greater Accra region (Ahadzie, 2007; Ayisi, 2000).

The respondents from the companies included Production managers, Quality Control Managers, Project managers, Managing Directors, Operation Managers, Commercial

Managers, Site Engineers, Factory Managers, Quantity Surveyors, Site Engineers and Planning Managers.

3.3.2 Sampling Technique

In order to obtain a representative sample for the study, the Snowball sampling technique was used to select 50 companies and the respondents for the study.

A snowball sample is a non-probability sampling technique that is appropriate to use in research when the members of a population are difficult to locate. A snowball sample is one in which the researcher collects data on the few members of the target population he or she can locate, then asks those individuals to provide information needed to locate other members of that population whom they know (Babbie, 2001).

Snowballing sampling technique was used to select the respondents because the researcher did not have much information about location and addresses and had to rely on the few known ones to arrive at the rest.

3.4 DATA COLLECTION AND INSTRUMENTATION

3.4.1 Data Sources

The approach for collecting data involved desk survey and field survey. The desk survey (literature review) formed an essential aspect of the research since it sets the pace for the development of field survey instruments using questionnaires, and interview (Fadhley, 1991). The field survey dealt with the collection of empirical data. A questionnaire survey approach to data gathering was adopted for the purpose of this research. Having conducted a thorough literature review and positioned the study within its theoretical context; an initial exploratory

interview helped to elicit relevant information from the respondents, preceding the main questionnaire survey.

3.4.2 Questionnaire Design

Before the questionnaires were developed, it was important to first establish the information to be gathered so that relevant questions are solicited (Oppenheim, 1996). The questionnaire was designed to include; scaled-response questions and close-ended questions. Attempt was made to keep the questions in the questionnaire in simple language void of technical terms to minimize potential errors from respondents. Similarly, the number of questions in each set was kept low as much as possible to encourage respondents to take their time in answering the questions. The format of the questionnaire was guided by considerations of appeal to respondents and ease of reading.

3.4.3 Content of the Questionnaire

The quality of the responses and response rate is traditionally affected by the type of questions and the way in which questions are articulated and presented. Anchored on this premise, it was therefore important to ensure that the right questions are asked, well understood and asked in the right way (Wahab, 1996). In all, fifteen (15) structured questions were asked, with the aim of exploring the level of knowledge and usage of the seven basic quality tools by producers of precast concrete products in Ghana.

Section „A“ sought to explore the background data about the respondents, which included information such as legal status of the firm, nature of business, age, turnover and type of pre-fab products they produce. Section B and C were questions which were mainly closed-ended type and sought to inquire about their level of knowledge and level of usage of the seven basic

quality control tools and section „D“ was questions on practical measures to improve quality control. The section “B, C and D” which were scaled-response type were asked to generate empirical data about the seven basic quality control tools.

3.4.4 Instrumentation and Response Rate

Considering the geographically dispersed nature of the concrete manufacturing companies, in Accra and Tema, the questionnaires were personally administered and also via the internet (e-mail). As suggested by Bell (1996), Dillman (2000), and (Frazer and Lawley 2000), the questionnaires were pre-tested using some selected companies in Accra and Tema, Ghana. The pretested questionnaires were analyzed and then revised based on the outcome and feedback from the analysis. The revised questionnaires were finally administered. For the study, 50 firms were selected using Snowball sampling technique method.

Forty-two copies of questionnaire were retrieved from the selected respondents representing a response rate of 84% and that was used for the analysis. The relative high response rate of 84% achieved was compared to that registered in the study by Owusu and Badu (2009), Easterly (1999), Galizia and Steinberger (2001), Ekow-Gyan (2002), and Eyiah and Cook (2003) which recorded respective response rates of 53.7 percent, 37 percent, 41 percent, 41.4 percent and 44 percent; suggesting the validity and adequacy of the response rate.

3.5 DATA PREPARATION AND ANALYSIS

3.5.1 Data Analysis

Largely quantitative data was gathered for the study. After cleaning up the data from the questionnaire survey and correcting the few mistakes that were detected in the filling of the questionnaires, the data were coded and fed into SPSS 19.0 for 9 (Windows version) to analyze the data using mean score ranking. The study employed the use of gap and quadrant analyses to determine if there were any significant differences in the mean scores for the importance and evidence of the level of knowledge and usage of the seven basic quality control tools. Having explored the level of knowledge and level of usage of the seven basic quality control tools, the importance (I)-evidence (E) gaps analysis was performed. It is necessary to rank these tools according to their importance (I)-evidence (E) from the viewpoints of producers of precast concrete products and it was based on results obtained from percentage coefficient of variance (i.e. standard deviation divided by mean multiplied by 100)

3.5.2 Reliability

Reliability refers to whether you get the same answer by using an instrument to measure more than once (Zhang, 2000). Reliability is a statistical technique to measure how reproducible the surveying instrument data is (Zhang, 2000). Four methods are used in measuring reliability namely; the split-halves, test-retested, alternative form and internal consistency methods (Zhang, 2000: Hair et al., 2006). In this study reliability was improved through the use of a survey protocol.

3.5.3 Construct validity

Construct validity is also statistical technique that measures the extent to which the items in a scale measures the same construct (Flynn et al., 1994). In other words, construct validity deals

with how well the concept of interest are translated to reality. To ensure construct validity in this study, operational measures were adopted from previous studies and based on conceptual definitions with strong theoretical grounding. Formal and informal pilot studies were also employed to ensure face and content validity using multiple source of evidence (Production managers, Quality Control Managers, Project managers, Managing Directors, Operation Managers, Commercial Managers, Site Engineers, Factory Managers, Quantity Surveyors, Site Engineers and Planning Managers).



CHAPTER FOUR

RESULTS AND DISCUSSION

4.1 INTRODUCTION

This chapter focuses on analyzing the gathered data from respondents through questionnaire. The descriptive statistics of the data provide quantitative insight to this investigation and as such provides an invaluable contribution to the aim of this research. To this regard, the analyses presented here are based on data from the demographics of respondents' firms and respondents, quality management practices of respondents' firms.

Also an in-depth analysis is presented to explore the level of knowledge and level of usage of the seven basic quality control tools by precast concrete products producers in Ghana. The results are actually structured to assess the level of knowledge and the level of usage of the seven basic quality control tools and also identify practical measures to improve quality control in the production of precast concrete product. The findings have been presented here in a statistical format such as charts and tables to enable examination and description on the pattern of the responses. For the seven basic quality control tools, the respondents were asked to indicate their level of knowledge and level of usage on a four-point Likert scale

(1= „not at all“, 2= „limited“, 3= „working knowledge“ and 4= „very good knowledge“) and (1= „not at all“, 2= „seldom“, 3= „frequent“ and 4= „all the time“) respectively. The study employed the use of gap and quadrant analyses to determine if there were any significant differences in the mean scores for the level of knowledge and level of usage of the seven basic quality control tools.

4.2 PROFILES OF RESPONDENTS / COMPANY -DEMOGRAPHICS

The results showed that most of the respondents had their formal and higher education from the Universities and Polytechnics. Six respondents representing 14.3% and eighteen respondents representing 42.9% had their education up to masters and first degree level respectively, thirteen were educated up to Polytechnic level, 13 representing 31% had theirs up to HND level and 5 representing 11.9% had theirs up to the Technician level.

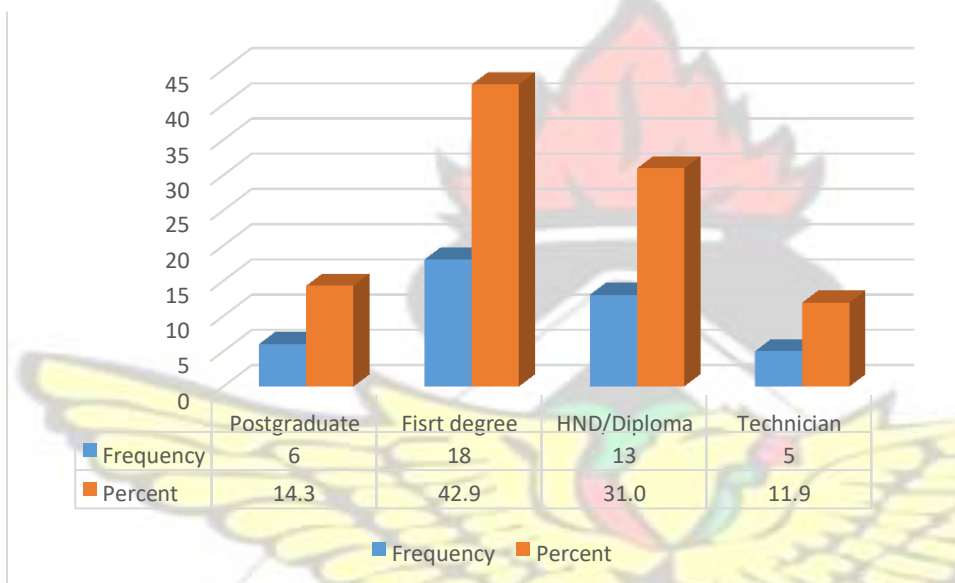

Fig. 4.1 level of Education

The result further revealed that respondents hold positions such as managing directors, project managers, quality control managers, production managers and others such as commercial managers, quantity surveyors with years of experience ranging between one and over twenty years.

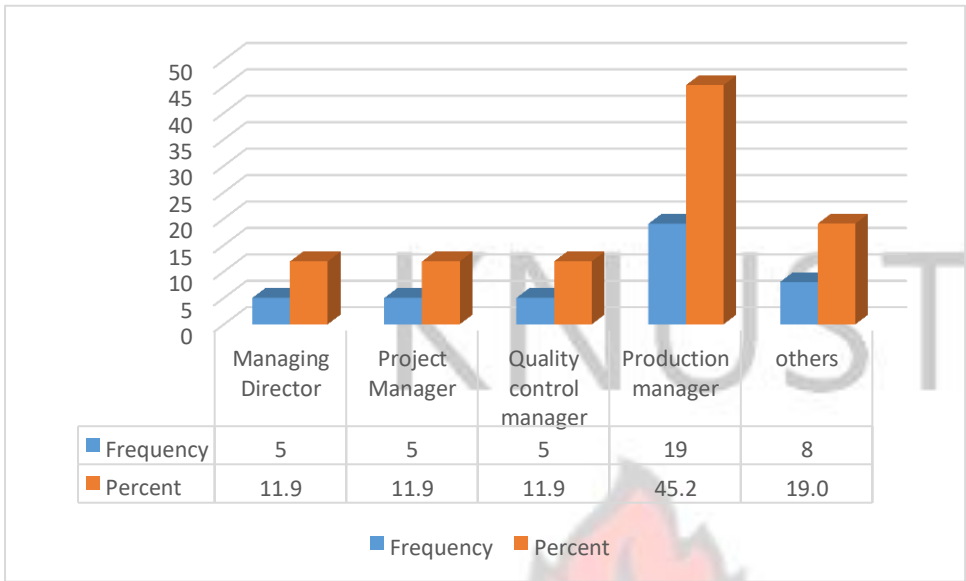

Fig.4.2 Job position

Five of the respondents were Managing Directors representing 11.9%, five project managers representing 11.9%, five of them are Quality control managers and nineteen production managers representing 11.9% and 45.2% respectively. Eight others representing 19% are one commercial manager and two Quantity surveyors, three Site engineers, one Factory manager

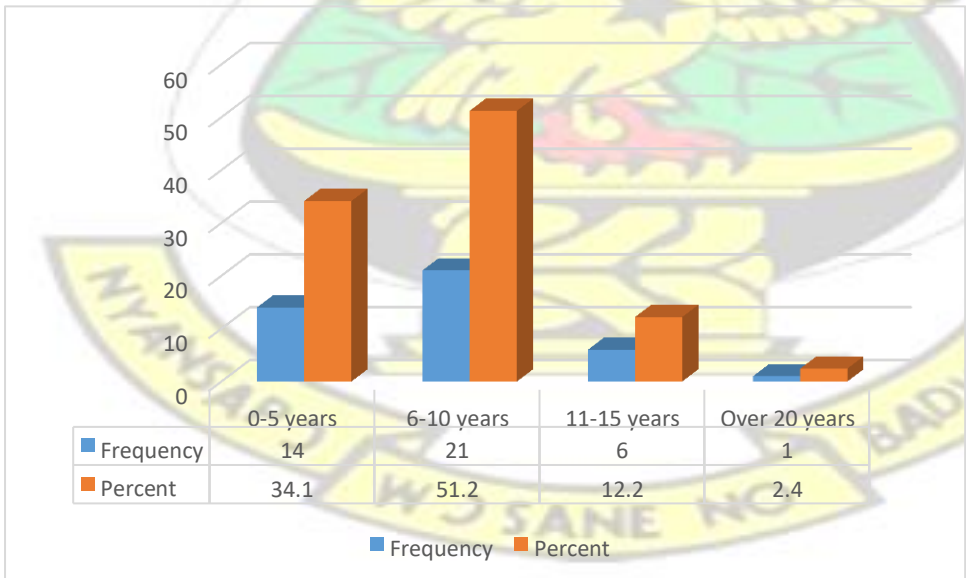

Fig. 4.3 Years of experience

and one Project Planning Engineer. Concerning their years of experience, it again came to light that fourteen respondents representing 34.1% have zero to five years of experience, twenty-one of the respondents representing 51.2% have six to ten years of experience, five respondents representing 12.2% have eleven to fifteen years of experience and one respondent with over twenty years of experience representing 2.4%.

On how long has your company been in existence, nine respondents representing 21.4% have been in existence for five years, nine respondents representing 21.4% have been in existence for six to ten years. Thirteen of the respondents representing 31% have been in existence for eleven to fifteen years and six of the respondents representing 14.3% have been in existence for sixteen to twenty years. Four respondent companies have over twenty years of existence and this represent 9.5%.One respondent representing 2.4% failed to indicate it years of existence.

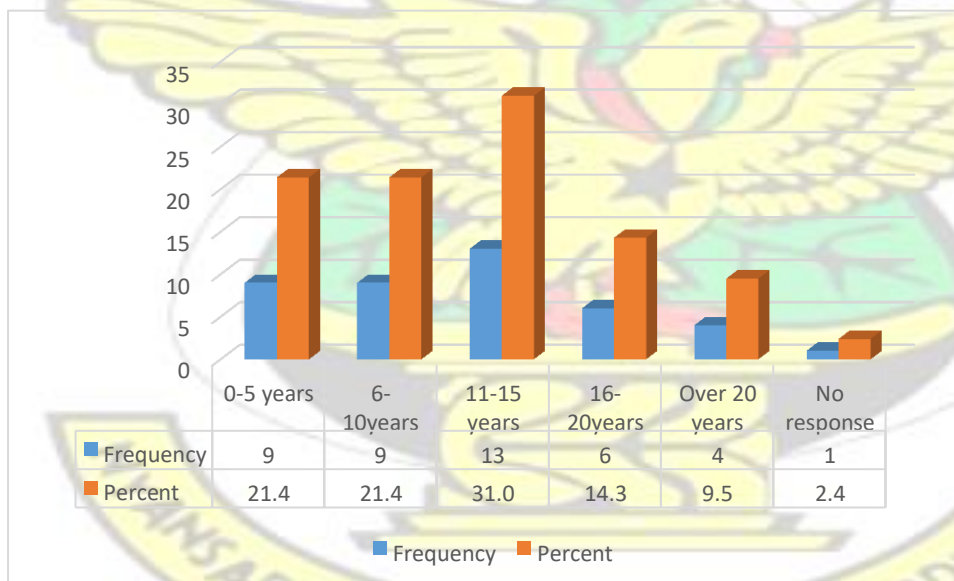

Fig.4.4 Year of existence of company

In summary, the information detailed above indicates that the respondents and respondents’ firms have reasonable experience in the industry. For that matter, it is accurate to conclude

that those who responded to the survey are sufficiently experienced in the concrete industry to provide data which is reliable and valid.

On the average annual turnover, three respondents representing 7.1% makes an average annual turnover of below 10,000 Ghana cedis, six respondent companies representing 14.3% makes an average annual turnover of 11,000-20,000 cedis. An average annual turnover of 21,000 to 30,000 Ghana Cedis is made by 13 respondents companies representing 31% with 19 respondents companies representing 45.2% making an average annual turnover of 30,000 Ghana cedis and above. One respondent representing 2.4% failed to indicate it turnover.

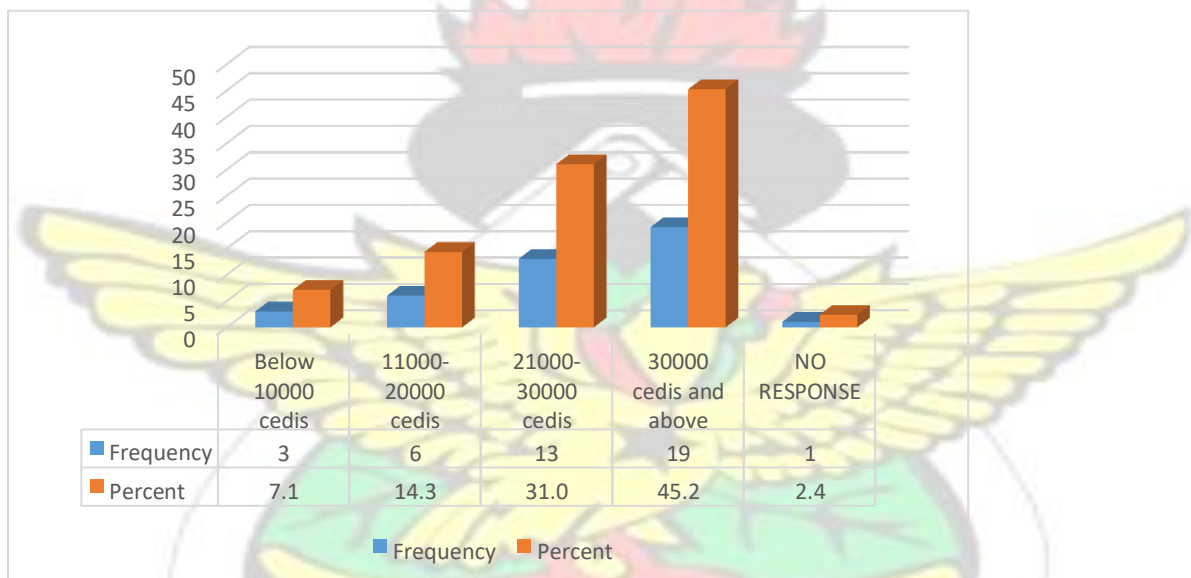

Fig.4.5 Annual Turnover

Respondents were asked to indicate whether or not they have quality control unit/department. The results are that only 16 of the companies representing 38.1% had a quality control units with 26 respondents representing 61.9% not having quality control unit/department (Quality unit, annual turnover, staff strength, budget and find a relation between them)

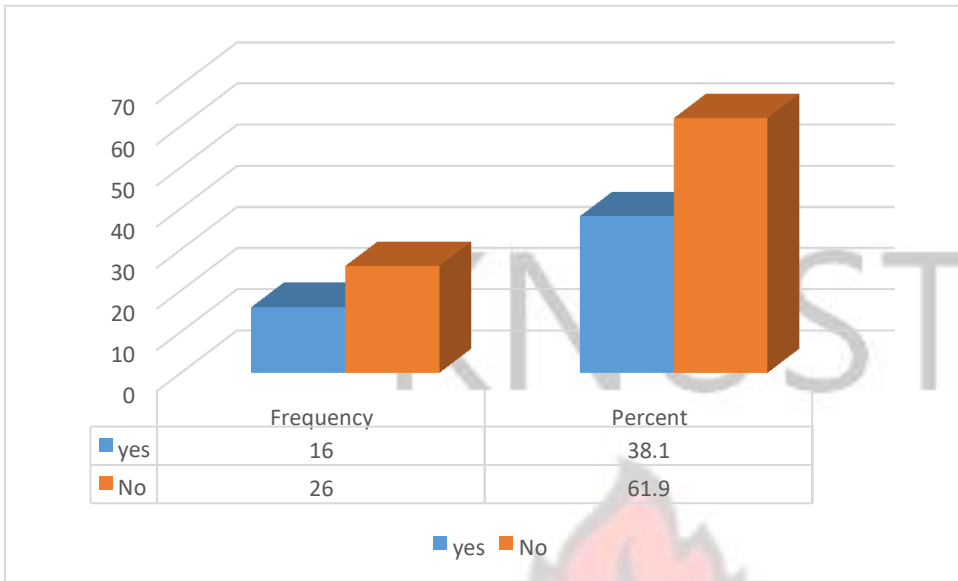

Fig.4.6 Quality Department/ Unit

On staff strength, 2 respondents representing 4.8% have staff of 2, 9 respondents representing 21.4% have a staff strength of 5 and 3 respondents representing 7.1% had staff strength of 8. 28 respondents companies representing 66.7% did not have quality control staff at all.

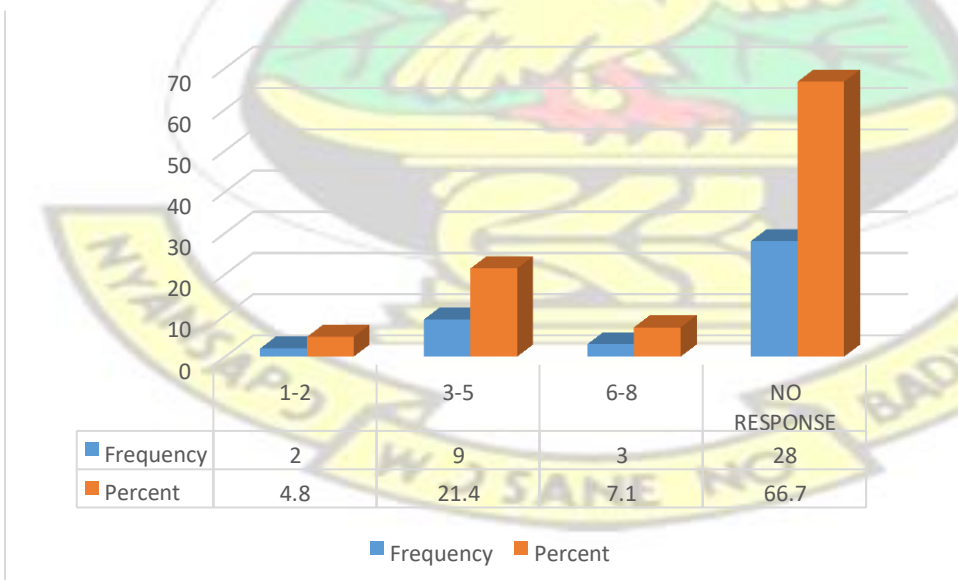

Fig. 4.7 Staff strength of Quality Control department

On budget for the quality control unit, 3 respondents representing 7.1% have budget below 10,000 Ghana cedis for it quality control unit and 5 respondents representing 11.9% have a budget of between 11,000 and 20,000 Ghana cedis for it quality control unit/department. Three respondents representing 7.1% have budget of between 21,000 and 30,000 Ghana cedis for it quality control unit/department, with just 1 respondent representing 4.8% having a budget of above 31,000. Thirty respondents representing 79.1% of precast concrete producers does not make budget provision for it quality control unit.

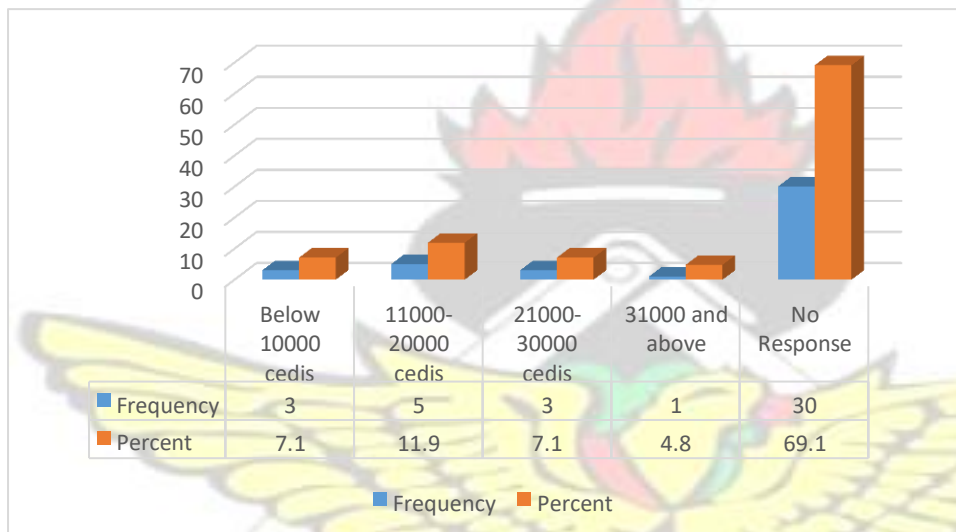
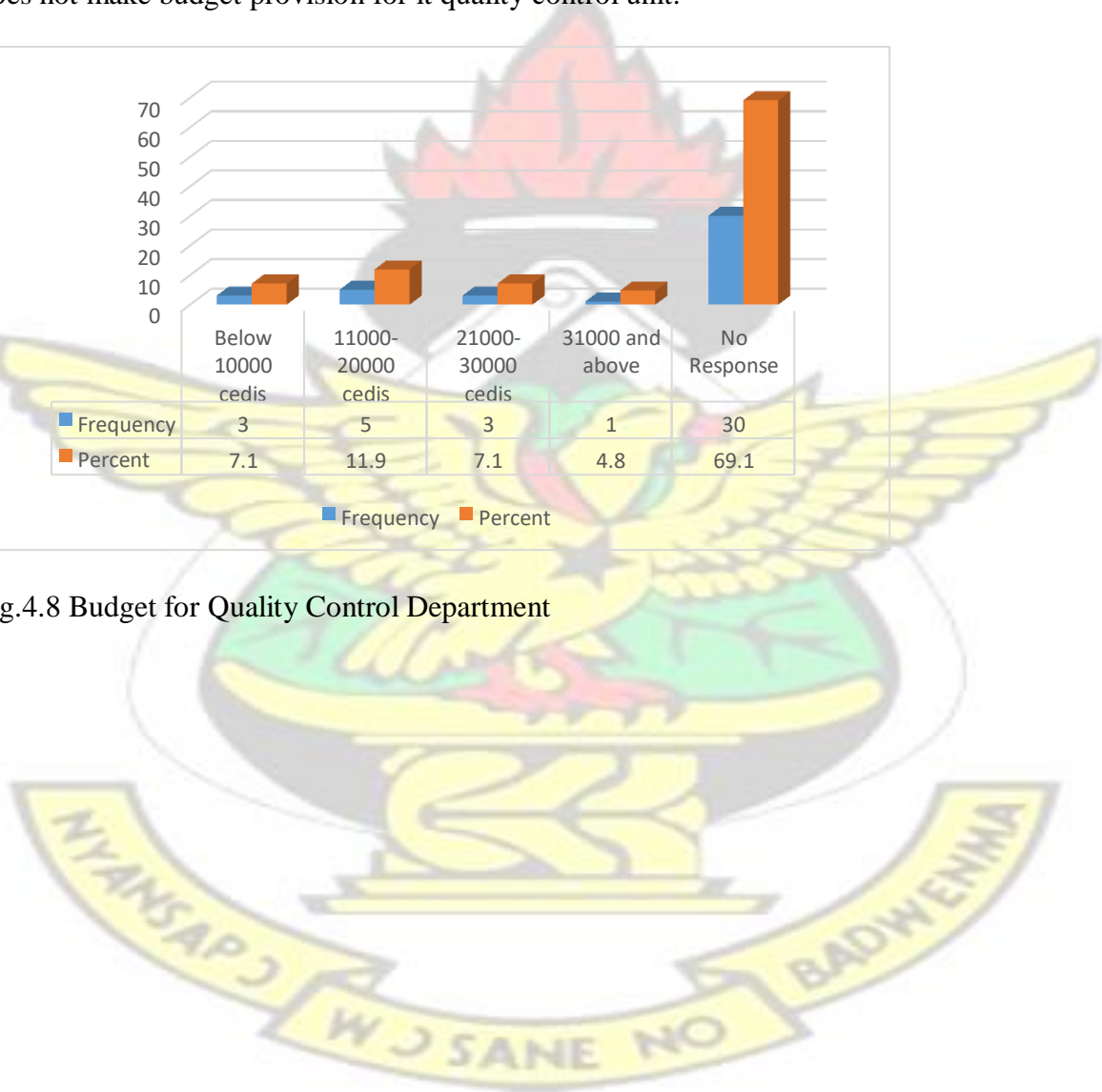

Fig.4.8 Budget for Quality Control Department



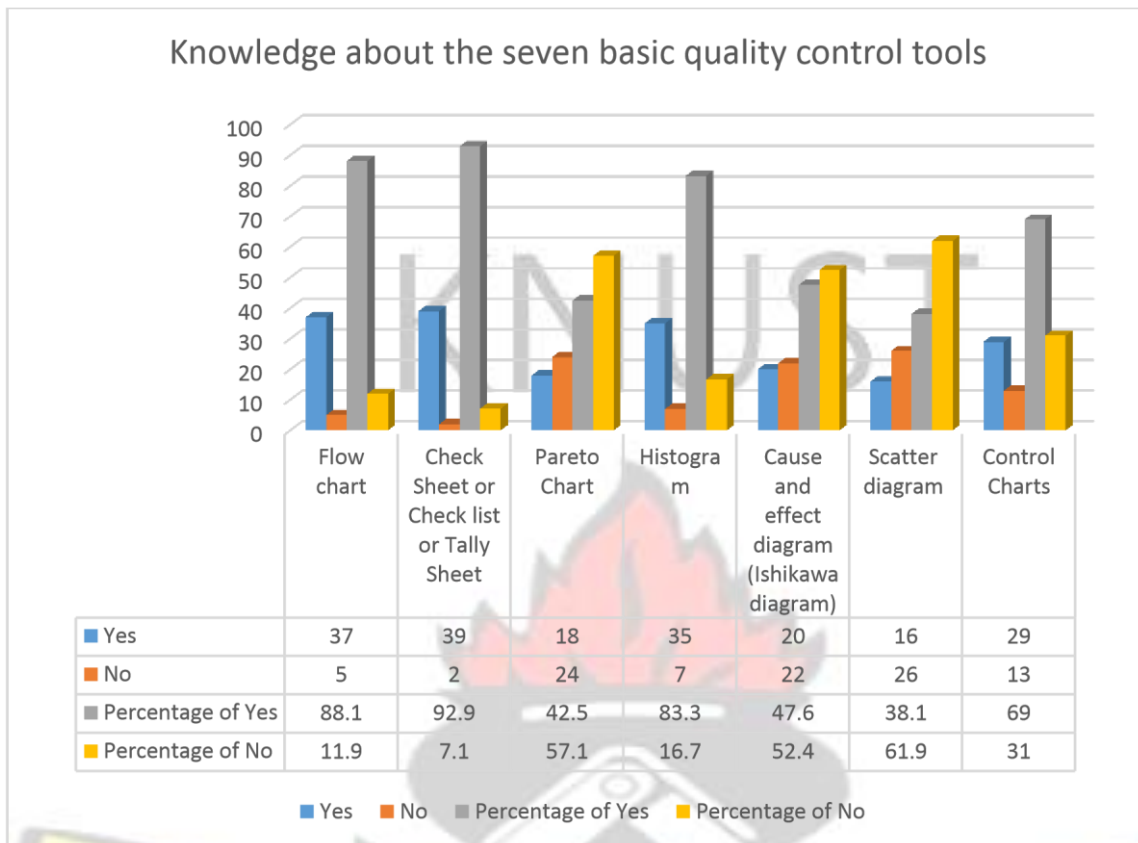

Fig. 4.9 Knowledge about the seven basic quality control tools

4.3 LEVEL OF KNOWLEDGE ABOUT THE SEVEN BASIC QUALITY CONTROL TOOLS

On the question of which of the seven basic quality control tools they know about, the responses are as follows for each of the tools. On Flow Chart, thirty-seven respondents representing 88.1% knows about it. Thirty-nine respondents representing 92.9% do know about Check sheet or Check list. Eighteen respondents which represents 42.5% knows about Pareto Chart, with 35 respondents representing 83.3% also knowing about Histogram. Cause and effect diagram (Ishikawa diagram) is known by twenty respondents and this represents 47.6%. Sixteen respondents representing 38.1% and twenty-nine respondents representing 69% know about the Scatter diagram and Control Charts respectively.

Respondents were asked to indicate their level of knowledge of the seven basic quality control tools Table 4.9 is a summary of the mean scores and standard deviations of the level of knowledge of the seven basic quality control tools by precast concrete producers in Ghana.

Table 4.1 Level of Knowledge about the seven basic quality control tools

Quality Control Tools	Mean Score	Std. Deviation	Rank
Check sheet	3.19	.890	1st
Flow Chart	2.95	.805	2nd
Histogram	2.93	.859	3rd
Control Charts	2.29	1.100	4th
Pareto chart	2.15	1.064	5th
Scatter diagram	2.07	1.184	6th
Cause and effect diagram or Ishikawa diagram	2.00	1.054	7th

The results showed that „Check sheet“ has mean score of 3.19 and ranked 1st, „Flow chart“ with mean score of 2.95 and ranked 2nd, „Histogram“ with mean score of 2.93 ranked 3rd, „Control Charts“ had mean scores of 2.29 ranked 4th, „Pareto Chart“ with mean score of 2.15 ranked 5th, „Scatter diagram“ with mean score of 2.07 ranked 6th with Cause and effect diagram having a mean score of 2.0 also ranked 7th. Generally, one can clearly see that respondents have some level of knowledge about the seven basic quality control tools especially the check sheet/list

4.4 LEVEL OF USAGE OF THE SEVEN BASIC QUALITY CONTROL TOOLS

Respondents were asked to indicate their level of usage of the seven basic quality control tools. Table 4.2 is a summary of the mean scores and standard deviations of the level of usage of the seven basic quality control tools by precast concrete producers in Ghana.

Table 4.2 Level of usage of the seven basic quality control tools

Quality Control Tools	Mean Score	Std. Deviation	Rank
Check sheet	3.19	.917	1st
Flow Chart	2.44	.940	2nd
Histogram	2.29	1.006	3rd
Control Charts	1.86	1.061	4th
Pareto chart	1.55	1.021	5th
Scatter diagram	1.46	.793	6th
Cause and effect diagram or Ishikawa diagram	1.45	.827	7th

The results showed that „Check sheet“ has mean score of 3.19 and ranked 1st, „Flow chart“ with mean score of 2.44 and ranked 2nd, „Histogram“ with mean score of 2.29 ranked 3rd, „Control Charts“ had mean scores of 1.86 ranked 4th, „Pareto Chart“ with mean score of 1.55 ranked 5th, „Scatter diagram“ with mean score of 1.46 ranked 6th with Cause and effect diagram having a mean score of 1.45 also ranked 7th.

4.5 GAP ANALYSIS OF LEVEL KNOWLEDGE AND LEVEL OF USAGE OF THE SEVEN BASIC QUALITY CONTROL TOOLS

To give a truer picture of the importance and evidence of performance of the level of knowledge and level of usage of the seven basic quality tools, a gap analysis between the knowledge and usage was performed. The gaps obtained for the respective tools are presented in Table 4.3. This was based on results obtained from percentage coefficient of variation (i.e. standard deviation divided by mean multiplied by 100). From the results it is clear that there are gaps (ranging from -15 to 3) existing in the level of knowledge and level of usage of the

seven basic quality control tools in the production of precast concrete products in Ghana. „Pareto Chart“ (16% gap; ranked 1st), „Histogram“ (15% gap; ranked 2nd), „Flow chart“ (12%; ranked 3rd), „Control Charts (9% gap; ranked 4th), „Cause and effect diagram or Ishikawa diagram“ (4% gap; ranked 5th) and „Scatter diagram“ (3% gap; ranked 6th) with „Check sheet“ (1% gap; ranked 7th). The results from the gap analysis clearly point to a situation that leads one to conclude that producers of precast concrete products are not taking full advantage of all the seven basic quality control tools in their operations even though they seem to have good knowledge of the tools. There is a very wide gap between the level of knowledge and level usage of the seven basic quality control tools in the industry in Ghana and this gap has to be bridged.

Table 4.3 presents the ranked results of the level of knowledge and level of usage of the seven basic quality control tools

Code	Quality Control Tools	Mean Score		Std. Deviation		% Gap		K-U Gap %	Rank
		K	U	K	U	K	U		
K-U 1	Check sheet	3.19	3.19	.890	.917	28	29	-1	7th
K-U 2	Flow Chart	2.95	2.44	.805	.940	27	39	-12	3rd
K-U 3	Histogram	2.93	2.29	.859	1.006	29	44	-15	2nd
K-U 4	Control Charts	2.29	1.86	1.100	1.061	48	57	-9	4th
K-U 5	Pareto chart	2.15	1.55	1.064	1.021	50	66	-16	1st
K-U 6	Scatter diagram	2.07	1.46	1.184	.793	57	54	3	6st
K-U 7	Cause and effect diagram or Ishikawa diagram	2.00	1.45	1.054	.827	53	57	-4	5th

This should serve as a source of worry to the precast concrete product industry and the construction industry in Ghana at large. Some of the reasons to this wide gap could be traced to the direct opposite information in table 4.4

In his paper, “On the use of the use of the seven basic quality tools for the improvement of construction industry: A case study of ready mix concrete production process, Aichouni, (2012) concludes that with the use of the seven basic quality tools in general, construction organizations can monitor, control and improve their processes in order to achieve breakthrough improvements and business results.

Aichouni (2012), stressed that the seven basic quality tools in general have demonstrated a great capacity in the improvement of manufacturing and services industries across the globe and the construction industry can benefit from these tools. On this grounds, the author of this research aligns and would want to encourage producers of precast concrete product in Ghana to as a matter of urgency look in the direction of training and enhancing the capacity of its staff in the use of these seven basic quality tools in their operation as mentioned as one of the ways to improve quality control. This when done would derive the following benefits;

- improving productivity;
- effectively detect and prevent errors in operations;
- prevention of unnecessary process adjustments;
- provide diagnostic information; and
- provision of information about process capability to meet customer requirements.

4.6 PRACTICAL MEASURES TO IMPROVE QUALITY CONTROL

This part of the analysis looks at what practical measures are being suggested to improve quality control in the operations of precast concrete producers.

Table 4.4 Suggested practical measures to improve quality control

Measures	Mean	Std. Deviation	Rank
----------	------	----------------	------

Process improvement guidelines and strategies	1.55	.705	1st
Incentives for good performance	1.50	.672	2nd
Regular inspections and audits	1.46	.745	3rd
Regular meetings between key stake holders i.e. design team, production team and users	1.43	.630	4th
Well defined roles and responsibility	1.41	.631	5th
Customer involvement	1.40	.665	6th
Communication between management and production unit	1.38	.661	7th
Clearly defined goals and objectives	1.37	.623	8th
Training and Education of work force	1.37	.767	9th
A clear policy on quality control	1.36	.618	10th
Employee involvement- Frontline workers involvement in decision making on product quality	1.34	.575	11th
Skilled workforce (Production)	1.33	.650	12th
Management commitment to quality	1.19	.594	13th

Here the results show that „Process improvement guidelines and strategies“ has mean score of 1.55 and ranked 1st, „Incentives for good performance“ with a mean score of 1.50 with rank of 2nd, Regular inspections and audit“ had a mean score of 1.43 and was ranked 3rd. „Regular meetings between key stake holders i.e. design team, production team and users“ had a mean score of 1.43 and ranked 4th. „Well defined roles and responsibility“ was ranked 5th with a mean score of 1.41 and „Customer involvement“ with mean score of 1.40 and ranked 6th. „Communication between management and production unit“ has a mean score of 1.38 and was ranked 7th, „Clearly defined goals and objectives was 8th with a mean score of 1.37. „Training and Education of work force“ also has a mean score of 1.37 and a standard deviation of 0.767 and was ranked 8th. „A clear policy on quality control“ has a mean score of 1.36 and ranked 9th, „Employee involvement- Frontline workers involvement in decision making on product quality, has a mean score of 1.36 and a ranked 10th. Skilled work force has

a mean score of 1.33 and ranked 12th with Management commitment to quality ranked 13th with a mean score of 1.19. From the above on practical measures to improving quality control, it could be realized that for every production to maintain its quality standards, the process improvement guidelines and strategies is very paramount and incentives for good performance cannot be over-looked.

4.7 QUADRANT ANALYSIS OF THE LEVEL OF KNOWLEDGE AND THE LEVEL OF USAGE OF THE SEVEN BASIC QUALITY CONTROL TOOLS

The Knowledge–Usage quadrant analysis was conducted in order to integrate the ratings of the current knowledge levels and current usage levels. This will help in identifying areas in which education and training is most needed to positively impact on practice. It can be seen from Table 4.3 (Gap analysis) that 1 out of the seven basic quality tools was rated above average in terms of knowledge and above average in terms of usage evidence. The remaining Six (6) were however rated below average in both level of knowledge and level of usage evidence ratings. On the basis of this, 6 of the seven basic quality control tools can be said to require immediate attention whilst the other 1 that ought to be maintained for continuous improvement. Similarly, all of them are to be reviewed for immediate attention to positively impact on practice.

Knowledge rating	Above Average	Quality control tools to maintain or deemphasize	Quality tools to Maintain for continuous improvement K-U 1
	Below Average	Quality tools to De-emphasize	Quality tools requiring Immediate attention K-U 2, K-U 3, K-U 4, K-U 5, K-U 6, K-U7
		Below Average	Above Average
		Usage Rating	

Fig. 4.5 Knowledge – Usage Quadrant Analysis

There is therefore the need for the precast concrete producers to begin to adopt the use of these 6 tools to enhance their operations. In this regard, more training and education in the use of the seven basic quality control tools is a necessity.

Having identified the quality management practices in the literature and level of knowledge and the level of usage of the precast concrete products companies about the seven basic quality control tools for quality control, a framework for improvement and implementation for quality control in the precast concrete firms is proposed.

CHAPTER FIVE

PROPOSED FRAMEWORK FOR QUALITY CONTROL

5.1 INTRODUCTION

This section discusses how to improve and implement Quality Management in the concrete production industry.

The frame work is based on the Quality control management literature, practical measures to improve quality control perceived by respondents in the precast concrete products industry.

Again, an insight to the need for framework is provided as well as the requirements needed for the design of the framework.

5.2 THE NEED FOR A FRAMEWORK

This section discusses how to improve and implement Quality Management in the concrete production industry.

The frame work is based on the Quality control management literature, practical measures to improve quality control perceived by respondents in the precast concrete products industry.

Again, an insight to the need for framework is provided as well as the requirements needed for the design of the framework.

According to Dale (2003), framework is usually a well-liked output which serves as a means of presenting ideas, concept, pointers and plans in a non-prescriptive manner. It allows users to choose their own starting point and specific course of action and priorities, and to develop the individual dimensions of TQM at a pace that suits the firm's situation and available resources. In this case, framework should be designed to represent the operations of the

organisation, the systems to enhance the activities that will be carried out bearing in mind the ultimate goal and style of managing quality in an organization.

Aalbrecht et al.(1991), provided reasons why a framework is needed to implement TQM,

namely:

- To illustrate an overview of TQM so as to communicate a new vision of the firm;
- To force management to address a substantial list of key issues which otherwise might not be addressed:
- To provide insight into the firm's strength and weaknesses; and
- Most importantly, to support implementation and to improve the chances that TQM adoption will be successful.

Najmi and Kehoe (2000) described the main characteristics of a framework as follows:

- Acts as a guideline.
- Result oriented.
- Literary and empirically supported.
- Time dependent.
- Continuous improvement oriented.

5.3 FRAMEWORK DESIGN REQUIREMENTS

In general, the following criteria can be considered as a guide in developing a good framework to suit the real estate developing characteristics (Yusof and Aspinwall, 2000):

- systematic and easily understood;

- Simple in structure;
- having clear links between the elements or steps outlined;
- general enough to suit different contexts;
- represent a road map and planning tools for implementation;
- answers “how to?” and not “what is?”; and
- Implementable at reasonable cost and time.

Development of any model or frame work has to start from initial idea and concept (Yusof and Aspinwall, 2000) and following that the framework for the implementation TQM is developed as a four-stage implementation process.

5.4 FOUR STAGES OF IMPROVEMENT AND IMPLEMENTATION

The four-stage process of implementing TQM in real estate firms are:

1. Start-up and commitment;
2. Implementation process;
3. Scheme for improvement;
4. Measurement for improvement.

Start-up and commitment

The start-up process which is also the planning process requires that top management commitment and involvement is consistent and visible for a successful implementation. It is the driving force for Quality control process. It also requires the top management setting up an effective quality management system. The quality system will serve as a spring board for full

implementation of quality management. The start-up process will inculcate quality culture and prevent cultural shock in the firm. Top management should convey the firm's vision, mission and strategic direction to employees consistently. Its strategies, planning process should effectively prepare the firm's environment for change process to Quality Management. The quality system is modelled to suit the management structure of the precast concrete product industry

The quality management system involves three processes: Management Planning, Quality Assurance and Quality control.

Management planning: This will consist of entire organization planning process including quality planning and strategic planning. This will be undertaken by the top management.

Quality Assurance and Control: This will be the responsibility of the middle management level, and with a precast concrete companies in Ghana it is the production team headed by the operations manager or quality control manager. Major responsibility is the supervision of work and Quality assurance according to the contractual requirements, this includes assuring the completion of the whole project scope in time and within budget and assuring quality of work conforms to the contractual requirements, this can be done using various methods like auditing, and analyzing Quality control results, developing and implementing project quality plan etc. The quality control output will be used in the Quality assurance work.

Implementation process

The Quality management improvement measures be considered at this stage and the QM practices should be practiced in the whole organization. Implementing Quality control management is implementing these practices.

Scheme for improvement

The evaluation of the implementation practices can easily be done by developing an assessment tool. The firm should identify deviations, problems and plan towards corrective actions.

Measurement for Improvement

The firm may develop its own specific measurement system that can better measure employee satisfaction, customer satisfaction, organizational efficient in the areas of reduction in rework/waste and quality cost, product /service quality and increase in revenue. The firm should continually measure its overall business performance, analyze and compare with the firm's goals and competitors overall business performance. Conclusions made after analysis of results if not favourable i.e. if implementation have not been effective, the PDCA cycle returns to the plan stage. On the other hand, if the implementation produces the desired results, the PDCA is still considers to consolidate the results and improve in the never ending PDCA cycle.

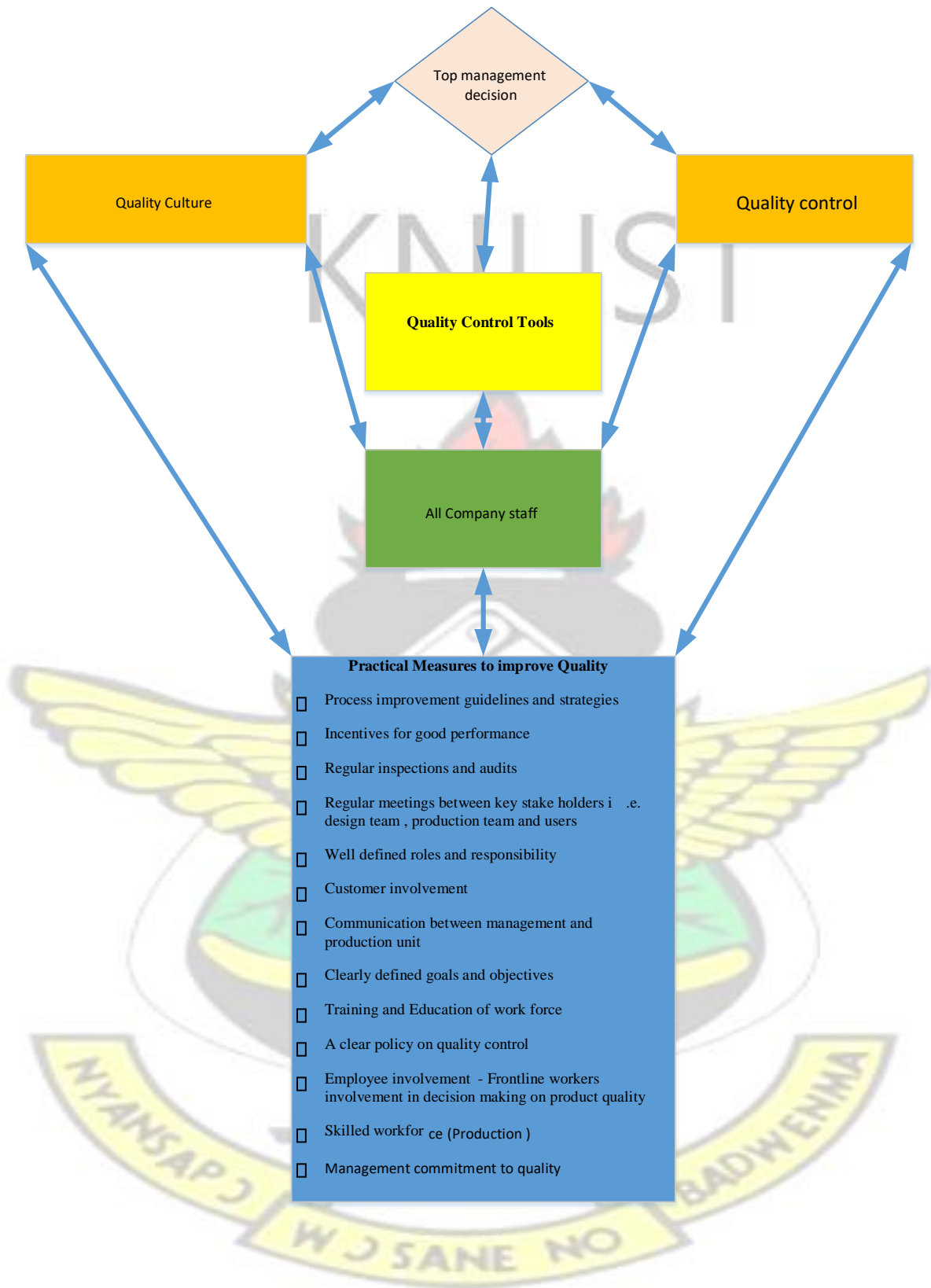

Fig 5.1 Framework to improve Quality Control

CHAPTER SIX

CONCLUSION AND RECOMMENDATIONS

6.1 INTRODUCTION

The aim of this research has been to explore the level of knowledge and usage of the seven basic quality control tools by producers of precast concrete products in Ghana and to achieve this, a number of objectives which were guided by research questions were set. In this chapter, the research questions and the objectives are revisited to bring into light the extent to which the aim of the study has been achieved throughout the various phases of the study. The chapter also provides conclusions and recommendations based on the findings of this research work. Again, the limitations that were encountered throughout the study are also brought to fore.

The specific questions to the study include:

1. What is the level of Knowledge of producers of precast concrete products in Ghana about the seven basic tools of quality?
2. What is the level of usage of the seven basic quality control tools in the production of precast concrete product in Ghana?
3. Which area of improvement of quality control is required by producers of precast concrete products?

These research questions served as guidelines in achieving the purpose of the study. The questions will now be discussed and related to the research results.

6.2 SUMMARY OF FINDINGS

Recapping what was earlier discussed in Chapter one of this report, the aim of this research was to explore the level of knowledge and usage of the seven basic quality control tools by producers of precast concrete products in Ghana. Three research objectives were set for this study. Objectives 1 and 2 were achieved through survey questionnaire conducted. Objective 3 was achieved through the literature review and respondents response to the section „D“ of the questionnaire.

6.3 COMMENTS ON OBJECTIVES ONE

The first objective was set to assess the level of knowledge of producers of precast concrete products in Ghana about the seven basic quality control tools.

From the results, it was realized that most of the respondents have some level of knowledge of the seven basic quality control tools. The „Check sheet, Flow chart and Histogram are the tools respondents have more knowledge about and the remaining four namely „Pareto chart, Cause and effect diagram, Scatter diagram and Control Charts not much considering the mean scores of the analysis as shown in table.4.1 and table 4.6.1.

6.4 COMMENT ON OBJECTIVES TWO

The second objective was set to assess the level of usage of producers of precast concrete products in Ghana about the seven basic quality control tools.

This objective has also been fulfilled in that the „Check sheet/check list“ is the most used tool in these firms followed by „Flow charts“ down to „Cause and effect diagram or Ishikawa diagram“ from the analysis. It is not surprising that the check sheets is the highest tool used because in almost all operations of production and construction check sheet is the favorable and easiest tool to use.

Results from the gap analysis shows a very close gap between the level of knowledge and level of usage of the Check sheet/check list indicating a very good knowledge –usage relation. However, from the analysis, other interesting results surfaced, indeed, one can see that respondents have some knowledge about flow charts and histogram which were the second and third highly ranked tools. The remaining four tools of the seven basic quality tools are not encouraging hence its usage is very poor as compared to the check list. This is an indication that the industry needs to do more in educating and encourage a continuous improvement in the knowledge and usage of the seven basic quality control tools in all operations of the industry.

6.5 COMMENT ON THE THIRD OBJECTIVES

The third objective was set to identify practical measures to improve quality control in the production of precast concrete products in Ghana.

This section of the questionnaire was in two parts, a structured question and an open-ended question. There was a list of thirteen practical measures to improve quality control for respondents to rank. It was discovered from the analysis that Process improvement guidelines and strategies, Incentives for good performance, Regular inspections and audits and Regular meetings between key stakeholders i.e. design team, production team and users were ranked 1st, 2nd, 3rd and 4th respectively. This is an indication that no better quality control can be achieved without critically looking at these measures. The remaining measures in the list must also be given credence.

In the TQM philosophy, total customer satisfaction is the goal of the entire system, and a persistent customer focus is what will get a firm to better performance. Customers may be either internal or external and for a construction organization to outperform its competitors, there is the need to anticipate and respond quickly to customers' demands with new ideas and technologies and to produce constructed facilities that satisfy or exceed customers'.

expectations. This gives emphasis to the fact that the visibility and support that management takes in implementing a total quality environment is critical to the success of TQM implementation (Low and Teo, 2004).

6.6 COMMENT ON THE FOURTH OBJECTIVES

The fourth objective was to propose a framework to improve quality control in the production of precast concrete products in Ghana.

The framework will provide a roadmap for implementation and improvement, and it is very dependent on a company needs and current quality initiatives. From the diagram it can be seen that the framework is simple and can be easily understood when various quality initiatives are implemented.

As shown in fig 5.1, this frame work provides an understanding of the components of Quality control success in a precast concrete products setting. This frame work considers the quality vision, senior management commitment, quality planning, and quality structure as starting points for a TQM process.

These feed into the organization's commitment to TQM, by practicing the various quality activities and thus implementation.

Evaluations of the quality initiative ensure challenges face to be noted and finally feedback about these results to increase the organization's involvement in improving quality. The framework proposed is derived from the quality management practices of these organizations, problems they faced in the implementation of their quality management and the practical measures perceived to be significant by the quality managers.

6.7 CONCLUSION

Although these firms are aware of the importance of quality control, their general level of knowledge and level of usage about the seven basic quality control tools is limited. Most of the concrete production firms do not use the seven basic quality control tools in their operations. Generally, it can be concluded that the firms do not have effective quality control management program in place to ensure customer satisfaction.

This study intended to identify practical measures to improve quality control in the production of precast concrete products in Ghana. Thirteen practical measures of improvement of quality control management were empirically identified, which are, Process improvement guidelines and strategies, Incentives for good performance, Regular inspections and audits, Regular meetings between key stake holders i.e. design team, production team and users, Well defined roles and responsibility, Customer involvement, Communication between management and production unit, Clearly defined goals and objectives, Training and Education of work force, a clear policy on quality control, Employee involvement- Frontline workers involvement in decision making on product quality, Skilled workforce (Production), Management commitment to quality. These measures are reliable, valid, and consistent and reflect with frequent cited success factors of quality management in firms implementing a quality management. It has also provided a new theoretical ground for studying the concept of Total Quality Management and contributed to knowledge on quality management in the production industry.

The study provided useful findings which will help quality practitioners in precast concrete products firms to implement their own quality management program that is unique to the industry. Yet again, from a managerial viewpoint, the findings of this study are useful to quality management practitioners in the industry, because it will give management a better idea and

also be able to devise their own quality management programs that are unique in order to achieve better performance and to sustain competitive advantages. In short, the results of this study offer practical hints to management on the most profitable areas to focus their attention on when practicing quality management in their firms.

The study concludes that planned and documented procedures for training of employees from top management to technical staff, and systematic implementation of the seven basic quality tools in production processes, together with a strong commitment of leadership to continuous improvement, are key success factors for precast concrete products industry to stay in business and the achievement of customer satisfaction and business excellence.

6.8 RECOMMENDATIONS

- Although the seven basic quality tools are widely being used in other developed nations, this study have shown that the seven basic quality control tools is not being used in the precast concrete product industry in Ghana. It is therefore being recommended that a systematic application of the seven basic quality tools be encouraged to enable a successful quality improvement process in this industry
- Quality management begins with top management commitment (Zhang, 2000; Concao et al., 2004; Sila and Ebrahimpour, 2002; Seraph et al., 1987), however, an appreciable percentage of firms top management are not committed to quality management program implementation and improvement. This can be achieved only if top management of these firms develop quality manual and see to its implementation, set objectives and provides requisite training for all of the employees in the firms.
- Successful implementation of Quality control management in the concrete product firms can be achieved through developing effective quality management system.

- Accomplishment in quality performance requires that top management should be dedicated to that ambition. In other words, those in top management must provide the initiative, direction commitment, resources for successful quality assurance practices and must support the quality program in the organization to be successful.
- The Precast Concrete Product Industry has numerous problems in getting quality performance as a result of the complicated nature of the industry. Quality management is being increasingly applied to the Precast Concrete Product Industry to solve quality problem.
- The implementation of a quality management required a culture of change and change in management behavior. The industry need to shift from their current culture to a TQM culture that focuses on quality as a key strategy.
- Finally, It is believed that attention to the seven basic quality control tools and the thirteen practical measures proposed will minimize difficulties related to the implementation of quality control and will enhance best performance in companies implementing quality management.

6.9 FUTURE RESEARCH

Future research should look at effective usage of the seven basic quality control tools to enhance the process of production of precast concrete products in the construction industry.

Again further studies should look at enhancing the knowledge about the seven basic quality control tools for the production of precast concrete products for effective construction.

And also, this studies was concentrated on only precast concrete products, however, further research can look at the effective use of the seven basic quality control tools for a combination

of precast concrete products as well as the delivery of affordable housing while using survey and case study approach.

Finally, this research has quantitatively established that there is a very low knowledge and usage of the seven basic quality control tools in the precast concrete products industry. Research to qualitatively confirm this findings and determine to what extent an increased level of knowledge and level of usage of the seven basic quality control tools will improve quality control in the precast concrete product industry is recommended.

6.10 LIMITATION OF THE STUDY

As this study contributes in a way of exploring the level of knowledge and the level of usage of the seven basic quality control tools by producers of precast concrete in Ghana, without doubt like any study or research it is also subject to some limitations. However, care was taken so that these limitations would not significantly affect this research. The major limitation that was faced during the research process was limited access to organizational information.

6.11 CONTRIBUTION TO KNOWLEDGE

An original contribution to knowledge is an important concern in any research (Walker, 1997). The problem is that the concept of originality could be arbitrary (Fellows and Liu, 2003; Sutrina, 2004). Walker (1997) has documented various ways to demonstrate originality such as development of new methodologies, tools and/or techniques, new areas of research, new interpretation of existing material, new application of existing theories to new areas or a new blend of ideas. Drawing on this background the contribution to knowledge of this research could be viewed in respect of its immediate contribution and what potential it may have in the future if further work is carried out (Ahadzie, 2007).

Thus, a contribution to knowledge from the findings reported in the thesis is the exploration of the level of knowledge and the level of usage of the seven basic quality control tools which hitherto no research has looked at. Most concrete producers do not have the knowledge about the tools and subsequently don't use them. The „Check sheet“ is the only basic tool which enjoy some appreciable usage in operation.

The body of knowledge in the use of the seven basic quality control tools in precast concrete production is unexplored. Subsequently concrete producers who want to monitor process, control errors and increase production have up until now had to rely on their conviction, an uninformed and largely subjective evidence. Thus, the findings that the seven basic quality control tools can be used to improve quality is a contribution to knowledge for the Ghanaian construction industry and learning.



REFERENCES

Al-Ani R. and Al- Adhmawi I. F. (2011). Implementation of Quality Management Concepts in Managing Engineering Project Site. A Case Study of Total Quality Management in a Manufacturing and Construction Firm, *Jordan Journal of Civil Engineering*, Vol. 5, No. 1; 89-106.

Ahadzie, D.K. (2007), "A model for predicting the performance of project managers in mass house building projects in Ghana", *PhD thesis*, University of Wolverhampton, UK: 2007.

Aalbrechtse, R.J., Hejka, J.A. and McNeley, P.K. (1991), "Total quality management (TQM): how do you do it?" *Automation*, August, pp. 30-32

Abdul-Rahman H (1995). The cost of non-conformance during a highway project: a case study. *Construction management and economics*, Vol. 13 pp. 23-32.

Ayandibu O. G. (2010). Quality Management and Socio-Economic Objectives in the Construction of the Guatrain. University of the Witwatersrand, Johannesburg. Pp 153.

Alarcon, L.F., & Ashley, D.B. (1992). Performance modeling: A methodology for evaluating project execution strategies (No. Source document 80). Austin, TX: Construction Industry Institute (CII).

Aspinwall, E., Liu, J., Joaquin D. & Hernandez D.,(2005), "A Comparative Study Of TQM Critical Success Factors In Manufacturing And Construction Uk Industries" Proceedings of the 4th International Conference on Quality and Reliability ICQR 2005, 9-11 August 2005, Edited by Lirong Cui, Albert H.C. Tsang and Min Xie, Beijing Institute of Technology, Beijing, China, pp. 135- 145

Arora, N. L. & Gupta, B. R, (2003) "Building Construction"

Ayandibu O. G. (2010). Quality Management and Socio-Economic Objectives in the Construction of the Guatrain. University of the Witwatersrand, Johannesburg. Pp 153.

An appraisal of mentorship within the black prime contractor of the emerging contractor development programme of South Africa. Johannesburg: University of the Witwatersrand; Unpublished MSc (Engineering).

Alarcon, L.F., & Ashley, D. B. (1992). Performance Modeling: A Methodology for Evaluating Project Execution Strategies. TX: Construction Industry Institute (CII).Pp 80.

Bryman, A. (2004), "*Social research methods*", 2nd edn. Oxford: Oxford University Press.

Bryman, A. (1992), "Quantitative and Qualitative Research: Further Reflections on their Integration", In Brannen, J. (ed.), *Mixing methods: Qualitative Research*, Avebury, Aldershot, pp. 57-78.

Barry, R. (1996) "The Construction of Buildings". Vol. 1, 3, and 4th edition, East-West Press, London

Babbie, E. (2001). The Practice of Social Research: 9th Edition. Belmont, CA: Wadsworth Thomson

Ban Kiong, ZainalAbidin Akasah, An Overview of Precast Concrete System for Building Maintenance: Malaysian Perspective, International Journal of Engineering Science & Advanced Technology, Volume-2, Issue-6, 1684 – 1689

Crosby, P.H. 1979. Quality is Free: The Art of Making Quality Certain. New York: New American Library

Crosby, P.H. 1984. Quality without Tears: The Art of Hassle-Free Management, McGraw- Hill: New York. 1st ed.

Crosby, P.H. 1988. The Eternally Successful Organisation: The Art of Corporate Wellness. McGrawHill: New York. 1st ed.

Crosby, P.H. 1990. Leading: The Art of Becoming an Executive. McGraw-Hill: New York. 1st ed.

Cameron, K.S., & Quinn, R.E. (1999). Diagnosing and Changing Organizational Culture. New York: Addison-Wesley Publishing.

Chase, G.W. (1998). Improving Construction Methods: A Story about Quality. Journal of Management in Engineering, 14(3), 30–33.

Cheng Hu, (2004). Construction Project Management. Second Edition; China Construction Industry. Pp 22-32.

Chin, K.S., Tummula, V.M.R., & Chan, K.M. (2002). Quality Management Practices Based On Seven Core Elements in Hong Kong Manufacturing Industries. Technovation, 22, 213–230.

Delgado-Hernandez, D. J and Aspinwall, E. M., Improvement Tools in the UK Construction Industry, Construction Management and Economics, Vol. 23, 2005, Pp. 965-977.

Dias, S. And Saraiva, P. M., 'Use Basic Quality Tools To Manage Your Processes', Quality Progress; Aug 2004, Vol. 37 Issue 8, Pp47-53.

Dale, B.G., (2003), "Managing quality" Blackwell Publishers Oxford.

Delgado-Hernandez, D. J and Aspinwall, E. M., Improvement tools in the UK construction industry, Construction Management and Economics, Vol. 23, 2005, pp. 965-977.

Duncan, JM; Thorpe, B and Sunmer, P (1990). Quality Assurance in Construction. Egbeonu, E. (2006).

Deming, W.E. 1982. Quality Production and Competitive Position, Massachusetts Institute of Technology, Center for Advanced Engineering Study, USA.

Deming, W.E. 1994. The New Economics for Industry, Government and Education: Prentice-Hall Europe.

Flynn, B. B., Schroeder, R. G. & Sakakibara, S. (1994), "A Framework For Quality Management Research And Associated Instrument", Journal of Operations Management, Vol., 11., pp . 339–366

Feigenbaum, A.V. 1983. Total Quality Control. McGraw-Hill Book Company. New York. 3rd ed

Gibb, A.G.F., & Isack, F. (2001). Client Drivers for Construction Projects: Implications for Standardization. Engineering Construction & Architectural Management, 8(1), 46.

Glass, J., Kendrick, C.K. & Baiche, B. (1999) Maximising opportunities for fabric energy storage, in Dhir, R.K. & Paine, K.A. Eds., Radical Design and Concrete Practices, Proceedings of the International Seminar held at the University of Dundee on 7 September 1999, Thomas Telford, London, pp.151-163.

Harris, F and McCaffer, R (1995). Modern Construction Management.4th Edition. Cambridge: Cambridge University Press.

Hair, J.F., Anderson, R.E., Tatham, R.L., & Black, W.C., (2006, 2007), "Multivariate Data Analysis with Reading", Prentice-Hall, Englewood Cliffs, NJ

Ilías Ortega and Søren Bisgaard, 'Quality Improvement in the Construction Industry: Three Systematic Approaches', Quality Management and Technology Reports Series, University of St. Gallen, Sweden, and Report (10), 2000.

Ishikawa, K (1985). What is Total Quality Control? The Japanese Way. Prentice-Hall, Inc.

Ishikawa, (1986), Guide to Quality Control (2 Ed.), Tokyo: Asian Productivity Organization, Pp. 32–34, ISBN 978-92-833-1035-8, OCLC 14169830

Ishikawa, K., (1986), Guide to Quality Control (2 Ed.), Tokyo: Asian Productivity Organization, P. 30, ISBN 978-92-833-1035-8, OCLC 14169830

Imbeah K.A, 2012 Framework for the Implementation of Total Quality Management (Tqm) In Real Estate Firms in Ghana

ISO. 2001. The ISO 9000 Family. <<http://www.iso.ch/iso/en/iso9000-14000/index.html>> accessed on 10 October, 2002.

Kotler, P. and Lee, N. (2005), “*Corporate social responsibility: doing the most good for your company and your cause*”, New Jersey: John Wiley & Sons

Love, PED and Li, H (2000). Quantifying the causes and costs of rework in construction, *Construction Management and Economics*. Vol. 18 pp. 479-490.

Low, SP and Wee, D. (2001). Improving maintenance and reducing building defects through ISO 9000. *Journal of Quality in Maintenance Engineering*, Vol. 7 No. 1 pp. 6-24

Low, SP; Tan, BK and Ang, AAL (1999). Effectiveness of ISO 9000 in raising construction quality standards: some empirical evidence using CONQUAS score. *Structural Survey*, Vol. 17 No. 2 pp. 89–108.

Loushine, T.W., Hoonakker, P.L.T., Carayon, P., & Smith, M.J. (2006). Quality and safety management in construction industry. *Total Quality Management and Business Excellence*, 17(9), 1771–1212

Liang, S., (2004). *Engineering Project Management*. Second Edition. China Dongbei. University Of Finance and Economics. Pp 71-79.

Loushine, T.W., Hoonakker, P.L.T., Carayon, P., & Smith, M.J. (2006). Quality and Safety Management in Construction Industry. *Total Quality Management and Business Excellence*, 17(9), 1771–1212.

Love, P.E.D., Mandal, P., & Li, H. (1999). Determining the Causal Structure of Rework Influences in Construction. *Construction Management and Economics*, 17, 505–517.

Leslie, Robert W. *History of the Portland cement Industry in the United States*. Chicago: International Trade Press, Inc, 1924.

RT and Taylor, FLM. (2003). *Management and Economics*, Vol. 6, pp. 50-57, McCutcheon, Employment and High-Standard Infrastructure. Johannesburg: Work Research Center for Employment Creation in Construction.

Mahmood, W.Y.W., Mohammed, W.H., Misnan, M.S., Yusof, Z. M., Bakri, A. (2006). Development of Quality Culture in the Construction Industry. *University Teknologi Malaysia, UTM Skudai 81310, Johor*. Pp. 11.

Montgomery, D., *Introduction to Statistical Quality Control*, 5th Edition, John Wiley, 2005.

Mcintyre, C., & Kirschenman, M. (2000). Survey of TQM in Construction Industry in Upper Midwest. *Journal of Management in Engineering*, 16(5), 67–70.

Mckim, R.A., & Kiani, H. (1995). Applying Total Quality Management to the North American Construction. *Cost Engineering*, 37(3), 24–28.

McNabb, D.E., & Sepic, F.T. (1995). Culture, Climate, and Total Quality Management: Measuring Readiness for Change. *Public Productivity and Management Review*, 18(4), 369–385.

Naoum, S.G. (1998), “Dissertation Research and Writing for Construction Students”, *Elsevier Butterworth Publications*, London.

Naoum, S.G. and Coles, D. (1997), “*Dissertation Guide: Instructions for Preparation, Control and Presentation of the Dissertation*”, School of Construction, South Bank University, UK.

Nankana, A. N., 'The Seven Magnificent: Simple, Quick and Cost Effective Tools for Continuous Improvement', New Age International Publishers, 2005, India.

Naoum, S.G. (2001). “Dissertation Research and Writing for Construction Students”. Oxford: Reed Educational and Professional Publishing Ltd.

Najmi, M., and Kehoe, D. F. (2000), “An Integrated Framework for Post-ISO 9000 Quality Development”, *Journal of Quality and Reliability Management*, 17 (3), pp 225-258

Nankana, A. N., 'the Seven Magnificent: Simple, Quick and Cost Effective Tools for Continuous Improvement', New Age International Publishers, 2005, India.

Owusu-Manu, D. and Badu, E. (2009), “Determinants of Contractors’ Investment Finance Strategy in Ghana: Conceptual and Empirical Explanations”, *Journal of Financial Management of Property and Construction*, 14 (1), 21-33

Ozeki, K. and T Asaka. 1990. Handbook of Quality Tools The Japanese Approach. Productivity Press: Cambridge. 1st ed.

Ofori, G (1988). Construction Industry and Economic Growth in Singapore. Construction

Ofori, G., Gu, G., & Briffet, C. (2002). Implementing environmental management systems in construction: Lessons from quality systems. *Building and Environment*, 37, 135–145.

On the Use of the Basic Quality Tools for the Improvement of the Construction Industry: A Case Study of a Ready Mixed Concrete Production Process, Mohamed Aichouni, Member SQC, *International Journal of Civil & Environmental Engineering IJCEE-IJENS* Vol: 12 No: 05 pp. 28-35

Paliska, G.; Pavletić, D. & Soković, M. 2008, Application of Quality Engineering Tools In Process Industry

Quality Management and Socio-Economic Objectives in the Construction of the Gautrain, Olabode Gbenga Ayandibu, Johannesburg, 2010

Raji Al-Ani and Firas I. Al-Adhmawi, Jordan Journal of Civil Engineering, Volume 5, No. 1, 2011

Reuben McKnight, 2004: A Brief History of Concrete. [The History of Concrete - InterNACHI](http://www.nachi.org/history-of-concrete.htm#ixzz32QPPFZXz)
<http://www.nachi.org/history-of-concrete.htm#ixzz32QPPFZXz>
Seeley, I. H. (1987) "Building Technology" London Macmillan Press,

Sinclair, J., & Collins, D. (1994). Towards A Quality Culture? International Journal of Quality And Reliability, 11(5), 19–29.

Slaton, Amy E. Reinforced concrete and the modernization of American building, 1900-1930. Baltimore, MD: Johns Hopkins University Press, 2001.

Victor Osei, 2013. The Construction Industry and Its Linkages to the Ghanaian Economy-Policies to Improve the Sector's Performance, Vol. 1, No.1, March 2013, Pp56-72. International Journal of Development and Economic Sustainability Published By European Centre for Research Training and Development UK (Www.Ea-Journals.Org)

William M. (2006). "Over-Controlling a Process: The Funnel Experiment". BPI Consulting, LLC. Retrieved 2010-03-17

Wahab, I.A. (1996), "Financing the Growth of Small Manufacturing Firms" A *Doctoral Thesis submitted* in partial fulfilment of the requirements for the award of Doctor of Philosophy of Loughborough University, UK

Ying C., (2010). Quality Control of Construction Projects. Savonia University of Applied Sciences, Business and Engineering, Varkaus. Pp. 53.

Ying C., (2010). Quality Control of Construction Projects. Savonia University of Applied Sciences, Business and Engineering, Varkaus. Pp 53.

Yong, K.T., & Pheng, L.S. (2008). Organizational Culture and TQM Implementation in Construction Firms in Singapore. Construction Management & Economics, 26(3), 237–248.

Zairi, M. 1991. Total Quality Management for Engineers. Cambridge: Woodhead.

Zairi, M. 1998. Effective Management of Benchmarking Projects Practical Guidelines and Examples of Best Practice, Butterworth-Heinemann: Oxford. 1st ed.

Zhang, Z., (2000), "Developing A Model of Quality Management Methods and Evaluation Their Effects on Business Performance", Total Quality Management, Vol. 11, No. 1, pp. 129-137

KNUST

APPENDIX A

QUESTIONNAIRE

COVER LETTER

Dear Sir/Madam,

Thesis – MPhil Construction Management

I am currently undertaking a Master of Philosophy degree in Construction Management at Kwame Nkrumah University of Science and Technology, Kumasi. In fulfillment of this, I am required to research a topic area and produce a thesis. The topic I have chosen is „Exploring the Level of Knowledge and Usage of the Seven Basic Quality Control Tools by Manufactures of Pre-Fab Concrete Products in Ghana. The objectives are:

1. To assess the level of knowledge of producers of precast concrete products in Ghana on the basic quality control tools.
2. To assess the level of usage of the basic quality control tools by producers of precast concrete products in Ghana.
3. To identify practical measures to improve quality control in the production of precast concrete products in Ghana

I would be very grateful if you could complete the attached questionnaire for this thesis. Needless to say, the information provided would be purely for academic purpose and will be treated with strict confidentiality and individual firms will not be identified

Yours Faithfully

Isaac Aidoo

0244676254 / 0203001236

Supervisor: Dr. Emmanuel Adinyira

Coordinator of Postgraduate Research Degrees

Dept. of Building Technology

College of Architecture and Planning

K.N.U.S.T – Kumasi

Tel. 0246753214

QUESTIONNAIRE

This questionnaire is designed for academic work and that respondent's information provided will be treated as confidential as possible. I will be very glad if you could sincerely answer the follow questions for me. Thank you.

SECTION A

Personal data

1. Name of Company (Optional).....

2. What is your level of education?

Postgraduate

First Degree

HND/ Diploma

Technician (CTC I, CTC II, CTC III)

3. What is your job position in the company?

Managing Director

Project Manager

Quality Control Manager

Production manager

Others (specify)

4. How many years experience do you have in the industry?

0-5 years, 6-10 years 11-15 years 16-20years , Over 20years

5. How long has your company been in existence?

0-5 years, 6-10 years , 11-15 years 16-20years , Over 20years

6. What is the average annual turnover of your company? Please tick appropriately

Below GH¢10,000

GH¢11,000-20,000

GH¢21,000-30,000

GH¢30000 and above

7. Does your company have a Quality Control Unit / Department? YES NO

If yes answer 8 and 9

If No skip 8 and 9

8. What is the staff strength of the Quality Control Unit? Please tick appropriately

1-2 , 3-5 , 6-8 , others (Please specify)

9. What is the budget for the Quality Control Unit?

Below GH¢ 10,000

GHC 11000-20,000

GHC 21000- 30,000

GHC31,000 and above

10. What type or kind of concrete pre-fab product do you produce?

Item	Pre- Fab Concrete Product Name	Tick
1	Paving Block	<input type="checkbox"/>
2	Solid and Hollow blocks	<input type="checkbox"/>
3	Paving Slabs	<input type="checkbox"/>
4	Culvert	<input type="checkbox"/>
5	Kerbs	<input type="checkbox"/>
6	Beams	<input type="checkbox"/>
7	Decorative blocks	<input type="checkbox"/>
8	Concrete roof tiles	<input type="checkbox"/>
9	Facing tiles	<input type="checkbox"/>
10	U-drains	<input type="checkbox"/>
11	P-trap gulley	<input type="checkbox"/>
12	Concrete transmission poles	<input type="checkbox"/>
13	Roman balustrade	<input type="checkbox"/>
14	Concrete fencing posts	<input type="checkbox"/>
15	Coping	<input type="checkbox"/>
16	Septic Tank	<input type="checkbox"/>
17	Bulk Head	<input type="checkbox"/>
18	Precast Inspection Chamber	<input type="checkbox"/>
19	Railway sleepers	<input type="checkbox"/>
20	Pre-stressed Floor slab	<input type="checkbox"/>

21	Concrete wall panel	<input type="checkbox"/>
22	Pre-cast steps	<input type="checkbox"/>

KNUST

SECTION B

1. Which of the seven basic quality control tools do you know about? Please tick appropriately.

Item	Tool	Tick
1	Flow chart	<input type="checkbox"/>
2	Check Sheet or Check list or Tally Sheet	<input type="checkbox"/>
3	Pareto Chart	<input type="checkbox"/>
4	Histogram	<input type="checkbox"/>
5	Cause and effect diagram (Ishikawa diagram or Fish bone)	<input type="checkbox"/>
6	Scatter diagram	<input type="checkbox"/>
7	Control Charts	<input type="checkbox"/>

2. Please express your level of Knowledge about the seven basic quality tools on a scale of 1-4. **1-Not at all, 2- Limited, 3- Working Knowledge, 4 – very good knowledge**

Item	Tool	Ranking			
		1	2	3	4
1	Flow chart	<input type="checkbox"/>	<input type="checkbox"/>	<input type="checkbox"/>	<input type="checkbox"/>
2	Check Sheet or Check list or Tally Sheet	<input type="checkbox"/>	<input type="checkbox"/>	<input type="checkbox"/>	<input type="checkbox"/>
3	Pareto Chart	<input type="checkbox"/>	<input type="checkbox"/>	<input type="checkbox"/>	<input type="checkbox"/>
4	Histogram	<input type="checkbox"/>	<input type="checkbox"/>	<input type="checkbox"/>	<input type="checkbox"/>

5	Cause and effect diagram (Ishikawa diagram or Fish bone)	<input type="checkbox"/>	<input type="checkbox"/>	<input type="checkbox"/>	<input type="checkbox"/>
6	Scatter diagram	<input type="checkbox"/>	<input type="checkbox"/>	<input type="checkbox"/>	<input type="checkbox"/>
7	Control Charts	<input type="checkbox"/>	<input type="checkbox"/>	<input type="checkbox"/>	<input type="checkbox"/>

KNUST

SECTION C

Please indicate your level of practice or usage of the seven basic quality control tools in your operations on a scale of 1- 4. **1- Not at all, 2-Seldom, 3-Frequent, 4- All the time**

Item	Tool	Ranking			
		1	2	3	4
1	Flow Chart: Production of a Flow Chart diagrams to Eliminate, Combine, Simplify and Change sequence in your operations	<input type="checkbox"/>	<input type="checkbox"/>	<input type="checkbox"/>	<input type="checkbox"/>
2	Check sheet: Using Check Sheet or Check list or Tally Sheet to record data on defects	<input type="checkbox"/>	<input type="checkbox"/>	<input type="checkbox"/>	<input type="checkbox"/>
3	Pareto Charts: A plot of graph of 80% of defect as against 20% of causes	<input type="checkbox"/>	<input type="checkbox"/>	<input type="checkbox"/>	<input type="checkbox"/>
4	Histogram: A plot of frequency of defect occurrences in your operations	<input type="checkbox"/>	<input type="checkbox"/>	<input type="checkbox"/>	<input type="checkbox"/>
5	Cause and effect diagram (Fishbone Diagram): Outlining major factors that can cause failure clearance and in turn the smaller factors that affect the major factors	<input type="checkbox"/>	<input type="checkbox"/>	<input type="checkbox"/>	<input type="checkbox"/>

6	Scatter Diagram: Plots to determine whether one variable is affected by another variable and whether the effect is positive or negative	<input type="checkbox"/>	<input type="checkbox"/>	<input type="checkbox"/>	<input type="checkbox"/>
7	Control charts: A plot of output over time to determine if process is within control limit.	<input type="checkbox"/>	<input type="checkbox"/>	<input type="checkbox"/>	<input type="checkbox"/>

SECTION D

1. What practical measures would you suggest to improving quality control?

Please indicate on a scale of 1-4. **1- Strongly agree, 2- Agree, 3- Disagree, 4 – Strongly disagree**

Item	Tools	Ranking			
		1	2	3	4
1	Employee involvement- Frontline workers involvement in decision making on product quality	<input type="checkbox"/>	<input type="checkbox"/>	<input type="checkbox"/>	<input type="checkbox"/>
2	Management commitment to quality	<input type="checkbox"/>	<input type="checkbox"/>	<input type="checkbox"/>	<input type="checkbox"/>
3	Skilled workforce (Production)	<input type="checkbox"/>	<input type="checkbox"/>	<input type="checkbox"/>	<input type="checkbox"/>
4	Communication between management and production unit	<input type="checkbox"/>	<input type="checkbox"/>	<input type="checkbox"/>	<input type="checkbox"/>
5	Training and education of the work force	<input type="checkbox"/>	<input type="checkbox"/>	<input type="checkbox"/>	<input type="checkbox"/>
7	A clear policy on quality control	<input type="checkbox"/>	<input type="checkbox"/>	<input type="checkbox"/>	<input type="checkbox"/>
8	Well-defined roles and responsibilities	<input type="checkbox"/>	<input type="checkbox"/>	<input type="checkbox"/>	<input type="checkbox"/>
9	Clearly defined goals and objectives	<input type="checkbox"/>	<input type="checkbox"/>	<input type="checkbox"/>	<input type="checkbox"/>
10	Process improvement guidelines and strategies	<input type="checkbox"/>	<input type="checkbox"/>	<input type="checkbox"/>	<input type="checkbox"/>
11	Regular inspections and audits	<input type="checkbox"/>	<input type="checkbox"/>	<input type="checkbox"/>	<input type="checkbox"/>
12	Incentives for good performance	<input type="checkbox"/>	<input type="checkbox"/>	<input type="checkbox"/>	<input type="checkbox"/>

13	Regular meetings between key stake holders i.e. design team, production team and end users	<input type="checkbox"/>	<input type="checkbox"/>	<input type="checkbox"/>	<input type="checkbox"/>
14	Customer involvement	<input type="checkbox"/>	<input type="checkbox"/>	<input type="checkbox"/>	<input type="checkbox"/>

2. In your own opinion, how can quality be improved in the Pre- Fab concrete product industry?

KNUST

Thank You

