

**INVESTIGATING THE POTENTIALS OF SAWDUST AND COCONUT
FIBER AS SOUND REDUCTION MATERIALS**

BY
NYUMUTSU JOSEPH
(BSc. Mechanical Engineering)

A Thesis Submitted to the Department of Mechanical Engineering, Kwame Nkrumah
University of Science and Technology, Kumasi in partial fulfilment of the
requirement for the award degree of

MASTER OF PHILOSOPHY IN MECHANICAL ENGINEERING

APRIL, 2019

CERTIFICATION

I hereby, certify that this submission is my own work towards the Master of Philosophy
and to the best of my knowledge, it contains no previously published work by another

person nor material which has been accepted for the award of any other degree of the university, except where due acknowledgement has been made in the text.

Nyumutsu Joseph
(PG 7255216)

.....
Signature Date

Certified by:

Dr. Anthony Agyei-Agyemang
(First Supervisor)

.....
Signature Date

Certified by:

Dr. P.Y Andoh
(Second Supervisor)

.....
Signature Date

Certified by:

Prof. G. Y. Obeng
(Head of Department)

.....
Signature Date

ABSTRACT

Noise reflectors, noise absorbers and noise barriers, are used for noise controlling purpose. This research conducted is to investigate local materials that may be used as sound reducing materials to offer solution to the existing environmental noise problem.

Samples were developed using sawdust, coconut fiber, expansive clay and dry plantain leaves applying silicon and starch as binding agents. Noise Reduction Coefficient (NRC), which is a ratio of the reduction levels of noise to the intensity of sound, was investigated by using an experimental setup including impedance tube, signal generator, sound level meter and a speaker. Experimental results indicated that, there is a better performance in the NRC of samples developed with particles less than 0.6 millimeters. NRC values obtained for Sawdust mixed with Expansive Clay ranged from 0.24 to 0.62 with the maximum value (0.62) occurring at 4.0 kHz frequency and that of Coconut Fiber mixed with Expansive Clay recorded NRC from 0.31 to 0.58 with the maximum value (0.58) occurring at 6.0 to 6.5 kHz frequency. It was found that, these materials have good acoustic properties and therefore can be used as an alternative to produce noise reduction materials. Utilization of these materials will also reduce environmental pollution and the effect of noise pollution on human health.

TABLE OF CONTENTS

CERTIFICATION	i
ABSTRACT	ii
LIST OF TABLES	v
LIST OF FIGURES	vi
LIST OF ABBREVIATION AND ACRONYMS	vii
ACKNOWLEDGEMENT	vii
CHAPTER ONE	1
INTRODUCTION	
1	
1.1 Background	1
1.2 Problem statement	2
1.3 Objective of study	2
1.4 Specific Objectives	3

1.5 Justification of study	3
CHAPTER TWO	4
LITERATURE REVIEW	4
2.1 Introduction	4
2.2 Sound and noise.....	4
2.3 Source of Noise	4
2.4 Effects of Noise	5
2.5 Acoustic Materials Available for Noise Control	8
2.6 Acoustic properties	8
2.7 Absorption materials	11
2.8 Behaviour of sound in a room	13
2.9 Fundamentals of Acoustics	14
2.10 Transmission loss and noise isolation	15
2.10.1 Parameters for Evaluating Acoustic performance.	17
2.10.2 Compression Rate (n)	18
2.11 Measurement and Duration	18
CHAPTER THREE	20
20 MATERIALS AND METHODS	20
3.1 Preparation of Mould.....	21
3.2 Instrumentation	21
3.2.1 Precision Digital sound level meter (DT8852)	21
3.2.2 Balance Scale	22
3.3 Binder Preparation	22
3.5 Extraction of Fibers	23
3.6 Sieve Analysis	23
3.7 Compression of Samples	25
3.8 Experimental Setup	28
CHAPTER FOUR	32
32 RESULTS AND DISCUSSION	32

CHAPTER FIVE	46
CONCLUSION AND RECOMMENDATION	46
5.1 Conclusion	46
5.2 Recommendation	46
REFERENCES	47
.....	APPENDIX
.....	52

LIST OF TABLES

Table 2.1 Equivalent Noise Exposure	8
Table 2.2 Noise Reduction Coefficients (NRC) for some common building materials	13
Table 3.1 Instrument Specifications:	22
Table 3.2 Particles distribution and Classification samples after sieving	24
Table 3.3 Mixture of Different Grade of Materials	25
Table 4.1 Noise level within a specific frequency range	33
Table 4.2 Sound level of the various materials.	34
Table 4.3 Sound level of the various materials.	35
Table 4.4 Sound level of the various materials.	36
Table 4.5 Calculated values of noise reduction coefficients	37
Table 4.6 calculated values of noise reduction coefficients.	40
Table 4.7 Calculated values of noise reduction coefficients	43

LIST OF FIGURES

Figure 2.1 Cause and Effect Relationships of Noise, (G B E A, 2001)	6
Figure 2.2 Porous Polycarbonate Material (PPM)	10
Figure 2.3 Absorption, Reflection, and Transmission of Sound.....	11
Figure 3.1 The mould used to form the test samples	21
Figure 3.2 Photograph of the samples after sieving	24
Figure 3.3 Photograph of the samples after sieving.	24
Figure 3.4 Small grade sawdust ((a) with dry plantain leaf layer and (b) without dry plantain leaf layer)	26
Figure 3.5 Mixture of small and big grade sawdust ((c) with dry plantain leaf layer and (d) without dry plantain leaf layer)	26
Figure 3.6 Mixture of small grade sawdust and coconut fiber ((e) with dry plantain leaf layer and (f) without dry plantain leaf layer)	27
Figure 3.7 big grade sawdust ((g) with dry plantain leaf layer with and (h) without dry plantain leaf layer)	27
Figure 3.8 Fine grade sawdust ((k) with expansive clay and (l) without expansive clay)	27
Figure 3.9 (m) Coconut fiber mixed with Expansive clay and (n) Coconut fiber mixed with fine grade sawdust.	28
Figure 3.10 Samples made with plantain leaf Layer.....	28
Figure 3.11 Experimental setup of the Impedance Tube	29
Figure 3.12 Experimental setup of the Impedance Tube	29
Figure 4.1 Noise Reduction Coefficients for small grade Sawdust at different frequencies.....	38
Figure 4.2 Noise Reduction Coefficient of a mixture of small and big grade sawdust at different frequencies.	39
Figure 4.3 Effect of the particle size on Noise Reduction Coefficient at different frequencies.....	40
Figure 4.4 Noise Reduction Coefficient for different samples at different frequencies.....	41
Figure 4.5 Noise Reduction Coefficient of fine grade sawdust with and without coconut fiber at different frequencies	42
Figure 4.6 Noise reduction coefficient of coconut fiber and fine grade sawdust compressed to 5 tons	44
Figure 4.7 Noise Reduction Coefficient of samples made with mixtures of Expansive Clay and fine grade sawdust, and with Coconut fiber.	45

LIST OF ABBREVIATION AND ACRONYMS

L_{Aeq}	Average noise equivalent
R_f	Flow resistivity
ASTM	E-1050 standard in the laboratory
dB	Decibel
dBA	average measure of the noise level
EPA	Environmental Protection Agency
Hz	Hertz
N.R.C	Noise Reduction Coefficient
NAC	Absorption Coefficient
SPL	sound pressure level
TL	Transmission loss
WHO	World Health Organization
ΔP	is the pressure drop across the layer

ACKNOWLEDGEMENT

My special acknowledgment goes to the Almighty God, who through his grace made this project a possibility. I also thank Him for the knowledge, strength and protection He gave me.

My sincere acknowledgment goes to my supervisor, Dr. Anthony Agyei-Agyemang, who through patient encouragement, guided me to the end of this project.

I also wish to express my immense gratitude to all lecturers and the technical staff of the Mechanical and Electrical Engineering Department, especially, Professor F. K.

Forson, Mr. Joseph Kwabena Gaddosey, Mr. Segbawu Gersion, and Mr. Francis Akueteh. I say God richly bless you, for your encouragement and contributions. My

gratitude also to my course mates, who encouraged, shared and advised me on some decisions I had to make, especially, Adom Quagrana. May God richly bless you.

KNUST



CHAPTER ONE

INTRODUCTION

1.1 Background

In today's modern industrial society, noise pollution has become a big problem. Workers are exposed to higher levels of noise above the approved level. Regardless of the nature of the work, everyone is affected. It has become a major source of health problem facing humanity and the environment (Gheorghe, 2013).

At the current state of development in technology, noise tends to be an inevitable problem in the society. Noise being an occupational hazard, controlling it and reducing it to the barest or tolerable levels for human comfort is a worthwhile challenge to be addressed using available local materials to cut down cost of importation of equivalent materials. Achieving a manageable noise level would depend on the material used. Industries should be very concerned about the effects of noise and also about finding solutions to reduce it to an acceptable level from its source (Chathurangani et al., 2013). Eliminating noise completely, may not be possible since the environment could not be changed entirely. Continuous exposure may pose health risk far beyond hearing damage. It is therefore necessary that measures are put in place to reduce it to a manageable level.

Some negative effects posed by noise pollution on human health includes the following: Hearing problems, Physical or mental losses, Annoyance, Tiredness among others (Murthy et al., 2007). It is therefore necessary to create public awareness and education

about the effects of sound pollution and how it may be reduced (Abdelfattah and Abd-Elbasseer, 2011).

Advanced techniques such as acoustical wall panel, barrier walls, soundproof curtains, duct silencers, and sound enclosures for industrial machinery are available in order to minimize the noise, but these techniques are expensive. In addition, most of these developed materials emit high CO₂ emissions during their manufacturing process (e.g. Glass fibers) (Dedigama and Shyaman, 2013).

1.2 Problem statement

Noise pollution causes lot of health problems. The health problems tend to reduce the man hours at work and raise health bills, which affect the economy.

Presently, sound absorption materials available for acoustic treatment commercially consists of glass or mineral-fiber material. However, reviewing the issue of health and safety, these materials when exposed to human can interfere with human health. It is therefore necessary to explore an opportunity to look for alternative less expensive local materials to be used as noise reducing material. Local materials for sound reducers have several benefits. They are renewable, abundant, cheaper, pose less health risk and safety concern during handling and processing.

1.3 Objective of study

The main objective of this project is to investigate the acoustic properties of some local materials such as sawdust and coconut fiber for noise reduction purposes.

1.4 Specific Objectives

The specific objectives of this project are

1. To Investigate the noise level within some specific frequency range using DT-8852 Precision digital sound level meter
2. To carry out experiments to determine the noise reduction levels at various frequency range.
3. To determine the Noise Reduction Coefficient (NRC) and to analyse which type of materials samples reduced the sound to the barest minimum

1.5 Justification of study

In view of the problems stated, preventing, reducing and isolating noise are very important for human health and the economy.

When this project is successfully completed and implemented, there are enormous benefits that would be achieved. The material developed in this study, may be used as an acoustical material for noise control. The availability of the sound reduction material developed would be at a lower cost compared to imported ones. It will help reduce environmental pollution. The availability of these local materials in large quantities results in their being burn or dumped into the environment. When these materials are collected and recycled the effect of noise pollution on human health and the burning of such materials, which causes environmental pollution, will be reduced. It will also create job opportunities for many people. Unemployment problem in the country will also bereduced since people may be contracted to collect these agricultural waste for a fee, not counting the setting up of a factory to produce the composite material.

CHAPTER TWO

LITERATURE REVIEW

2.1 Introduction

The purpose of this project is to investigate into local materials, which could be used to reduce sound or noise to the barest minimum. This chapter provides information about sound and noise, sources of noise, its effects and various acoustical materials available for the control of noise.

2.2 Sound and noise

Sound can be explained as a kind of vibration that propagates as mechanical wave of pressure and displacement through a medium. It is anything that we hear due to vibration of air.

Noise can be explained as unwanted sound measured in decibel (dB) using a logarithmic scale (Tsaloglidou et al., 2015). Noise, can also be explained as unwanted sound resulting from human activities, measured in decibel (dB) (Kim, 2015). Noise has become a serious environmental problem with the development in technology (Rozli et al., 2010). The difference between sound and noise actually depends on the listener and the circumstance at that particular moment. For example, someone whose favourite music is playing may listen and enjoy it, but the one who is not into such music may hear it and would become annoyed. (Hansen, 2001).

2.3 Source of Noise

Environmental noise has become an important everyday problem in modern living environments. Noise from factories, airports, and heavy traffic does not only bring about discomfort to people close to the source of the noise, but also cause disturbance and serious health related effects and diseases. The sources of noise that caused damage in the residential indoor environment can be grouped into noise generated internally

and noise generated externally. Noise transmitted by air between households, home appliances, etc. are examples of noise generated inside offices and apartments, while noise generated externally includes automobiles (on roads), railway noise and aircraft (Kim, 2015).

2.4 Effects of Noise

There are different effects of noise. Noise can disturb human activity by causing distraction or by physically interfering with it. It is only when the effects of a sound are undesirable that it may be termed as noise (Kumar et al., 2004). Noise induced hearing loss (NIHL) is not a concern at the levels of noise experienced by neighbours of noise emitting facilities. It is a potential hazard when people are exposed to noise levels above 80 dB(A) over very long periods of time. The potential risk to workers is dealt with by the Health and Safety Executives and in some cases by Local Authorities.

The extent of damage will depend on the level, how loud it is and the frequency at which one is operating, since high frequency sound level may cause more hearing loss than low ones. The people involved are at a potential risk, which must be addressed by the various Local Authorities, and Safety and Health executives (G B E A, 2001). Noise effect of physiological other than hearing loss when individuals are exposed to noise level above 85 dB continuously has resulted in chronically high blood pressure. The strongest impact of noise effect on cardiovascular system was observed from the studies of blood pressure in occupational settings. Green et al, (1991), found that there is a slight increase in diastolic and systolic blood pressure in people between 25 and 44 years of age due to exposure to noise level more than 85 dB. It was observed that there is a slight decrease in systolic blood pressure and no blood pressure effect on that of the diastolic (U-Dominic et al., 2014).

In most cases, noise in general is mostly produced by human activities, machines and machine tools. The noise produced may vary, based on the medium through which the noise generated. Figure 2.1 shows the various sound levels produced by various machines used in performance of activities on daily basis and the variation of the sound pressure level (G B E A, 2001).

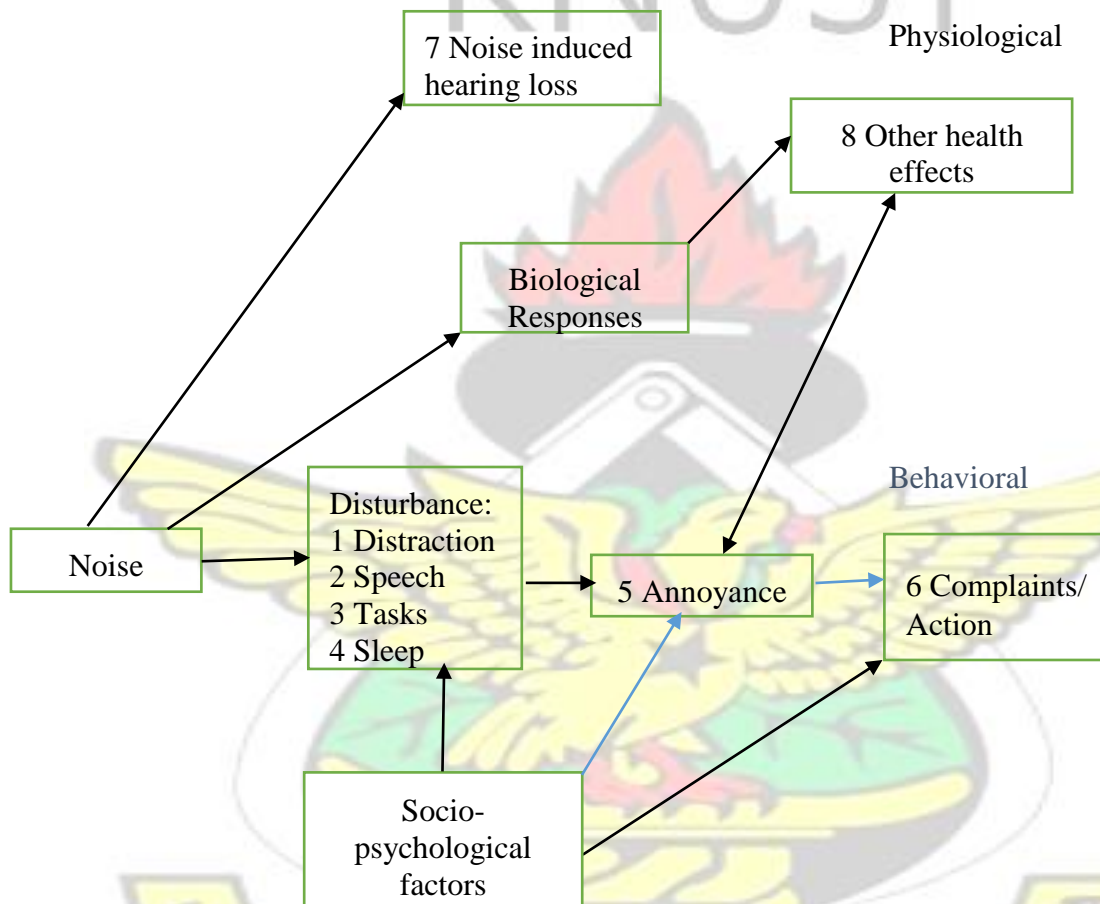

Figure 2.1 Cause and Effect Relationships of Noise, (G B E A, 2001)

(Mitchell, 2001) had made a clear distinction between disturbance and annoyance. In situation where one is prevented from carrying out ones daily activities such as learning (reading), sleeping, meditating, conversing (communication), listening to live programs on airwave, etc., the displeasure resulting from this noise level is annoyance. Annoyance is therefore the product of disturbance. Disturbances can be analyzed while annoyance is measured by conducting a survey. Other effect of sound radiated are

vibration of items such as things on shelves, windows, door post, things hanging on walls and this may increase to the level of annoyance (Mitchell and Environment Agency, 2001).

The extent of hearing loss effect depend on how long, how loud and also how high the level of the frequency is, since high frequency of sound is more damaging compared to the low frequency level noise (S W A, 2011).

Decibels (dB) scale is a logarithmic scale used to measure the level of sound, and is not the same as the normal numbers. Because of this it cannot be subtracted or added in the usual way. The representation of the scale is twice the energy of the sound in an increase of 3 dB. What it means is that, the number of hours of exposing a worker to the level of the noise is decreased by half for every increase in the level of noise by 3dB, if the same level of noise is to be expected (S W A, 2011).

Table 2.1 shows the duration one without any hearing protector can be exposed before exceeding the standard.

Table 2.1 Equivalent Noise Exposure

Equivalent Noise Exposure LAeq-85h = 85 dB (A) Noise	
Level dB (A)	Exposure Time
80	16 hours
82	12 hours
85	8 hours
88	4 hours
91	2 hours
94	1 hour
97	30 minutes
100	15 minutes
103	7.5 minutes
106	3.8 minutes
109	1.9 minutes

112	57 seconds
115	28.8 seconds
118	14.4 seconds
121	7.2 seconds
124	3.6 seconds
127	1.8 seconds
130	0.9 seconds

Source: (S W A, 2011).

2.5 Acoustic Materials Available for Noise Control

In controlling noise, these four types of noise control materials are mostly used. These materials include, Sound absorbers, sound insulators for airborne sound, vibration isolators and dampers.

2.6 Acoustic properties

Materials available for acoustic treatment have different properties as far as noise reduction is concerned. Several research works dealt with the acoustical properties of materials. Asdrubali. (2007), investigated the acoustical properties of materials developed from recycled tyre granules bound together with a binder. Results showed that, the Coefficient of Absorption decreases with the increase in grain size. It was found that better performance of sound absorption coefficient can be achieved using small size rubber granules. Compaction ratio on the grain sizes seems to have effect on the reduction of the absorption coefficient particularly between 2 kHz and 6 kHz. Damping properties of a rubber in some cases has been proposed together with carpet waste fibers in order to optimize the impact of sound insulation because of its intrinsic properties such as low internal sound speed, high specific weight, and its ability to absorb sound and dissipate energy. Performance after installation last for many years since its resilience changes very little thus keeping insulating performance constant.

Rwawiire et al. (2017), investigated cellulose nonwoven natural fabric (barkcloth) to determine its sound absorption and thermal properties. It was found to have higher sound absorption properties at higher frequencies. Increasing the layers showed positive results towards sound absorption property and very poor thermal conductivity, when used as headliners inside vehicles.

Acoustic properties of porous polycarbonate material (PPM) fabricated by additive manufacturing was considered by Liu et al. (2016). Results indicated that, at low frequencies significant reduction of sound absorption performance can be achieved by reducing air gap and increasing the slanted angle. Figure 2.1 shows design of test samples.

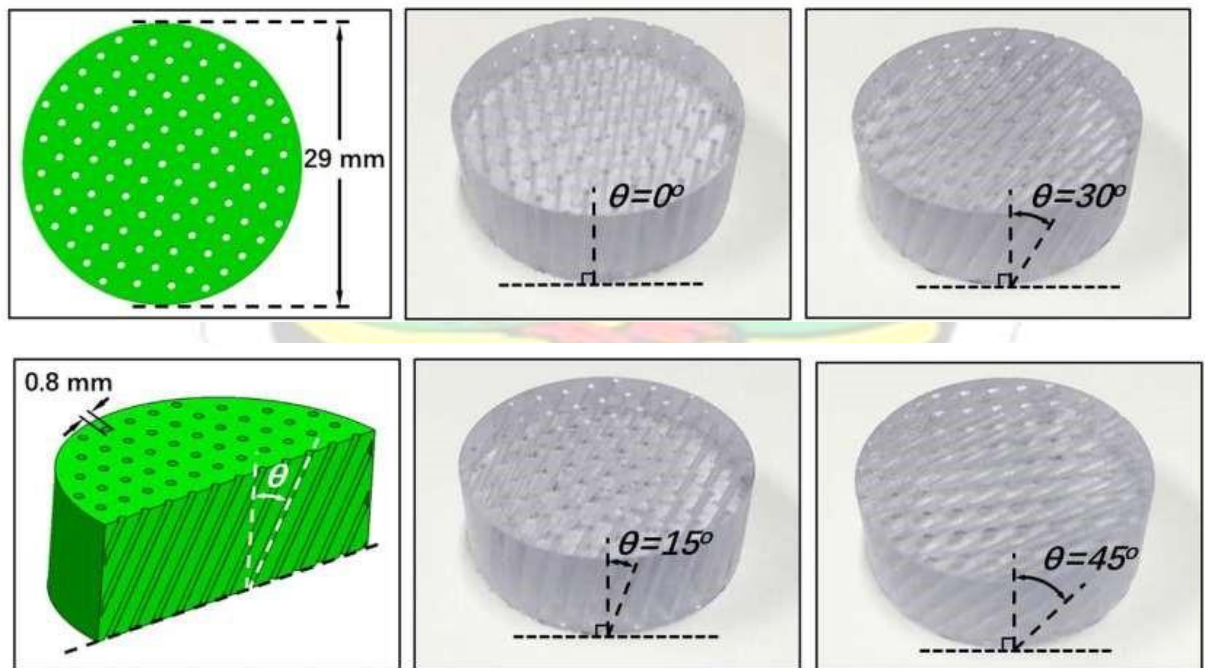

Figure 2.2 Porous Polycarbonate Material (PPM)

Maderuelo-Sanz et al. (2013), investigated new materials and their acoustical properties. Materials considered were ground tyre rubber having different particle sizes mixed with polyurethane resin. Results obtained showed that, porous

absorbers with small thickness has high sound absorption reduction. The acoustic performance of the material compared to some of the current models for the prediction of their absorptive properties depends on the flow resistivity, tortuosity, the porosity and the thickness.

The absorption properties of different waste layers of a tea-leaf-fiber with and without backing of woven textile cloth were investigated by Ersoy and Küçük (2009). It was found that, a sample with backing with a thickness of 1 cm gave sound absorption almost the same as one provided with six layers. The sound absorption properties of the material developed increased as thickness and the backing increases.

The properties of Sound absorption capacity of materials made of perforated composite panels of fiberboard sawdust, recycled rubber, and high density polyethylene were investigated by Xu et al. (2018) using high-density polyethylene as a binder. The results indicated that, the structural parameters: depth of cavity, size of the hole and the perforation ratio affected the sound absorbing properties.

2.7 Absorption materials

Since the Acoustic material developed would be used to partition buildings or installed on the walls of rooms, it would be necessary to consider the behaviour of sound under the following circumstances. In an event where the sound is incident on a material such as a wall, the following eventually takes place. The sound may be either transmitted, absorbed or reflected, as shown in Figure 2.2. When these materials are used to insulate the walls of the rooms, they may give perfect absorption and transmit the sound as well. Considering a window opening, Sound Absorption Coefficient (α) is considered as one

(1). When $\alpha = 1$, then it means the material is a total absorbent because none of the incident sound is reflected. If $\alpha = (0)$, then it means a total reflection (Jayamani et al., 2013).

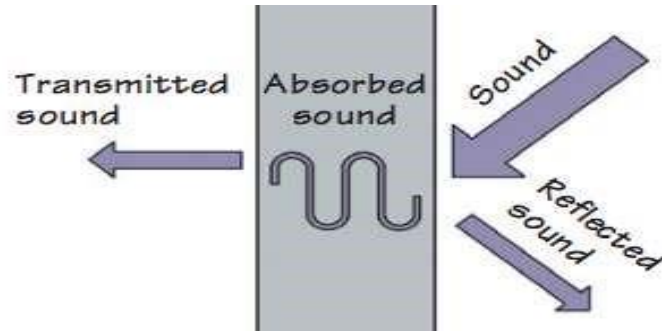

Figure 2.3 Absorption, Reflection, and Transmission of Sound

Source: (Cao et al., 2018)

The absorption coefficient (α) is defined as the ratio of sound absorbed by the material in dB (A) to the level of sound absorbed without the material. The Noise Absorption Coefficient (α) can be determined using the formula:

$$\text{Noise Absorption Coefficient: } \alpha = \frac{E_a + E_t - E_r}{E_i} \quad 1$$

Where, α is Noise Reduction Coefficient E_a is sound energy absorbed E_i is the sound energy without the acoustic material E_r is the sound energy reflected E_t is the sound energy transmitted.

Source: (Tang and Yan, 2017)

2.5 Noise Reduction Coefficient (NRC)

Noise reduction Coefficient (NRC) is the means used to measure the effectiveness of materials to absorb sound or prevent them from reflecting sound. This is the percentage of sound, the acoustic material absorbs without reflecting back into the enclosure. Table 2.2 shows Noise Reduction Coefficients (NRC) for some common building materials.

Table 2.2 Noise Reduction Coefficients (NRC) for some common building materials

Material	NRC
Brick, painted	.00 - .02
Brick, unpainted	.00 - .05
Carpet, indoor-outdoor	.15 - .02
Carpet, heavy on concrete	.20 - .20
Carpet, heavy on foam rubber	.03 - .55
Concrete (smooth), painted	.00 - .05
Concrete (smooth), unpainted	.00 - .20
Concrete block	.05
Concrete block unpainted	.05 - .35
Cork, floor tiles (3/4 inches thick)	.10 - .15
Cork, wall tiles (1 inches thick)	.30 - .70
Drapery, light weight (10 Oz)	.05 - .15
Drapery, medium weight (14 Oz) velour draped to half	.55
Drapery, heavy weight (18 Oz) velour draped to half	.60
Fabric on gypsum	.05
Fiberglass, 3-1/2 inches batt	.90 - .95
Fiberglass, 1 inches semi-rigid	.05-.75
Glass	.05 - .10
Gypsum	.05
Linoleum on concrete	.00 - .05
Marble	.00
Plaster	.05
Plywood	.10 - .15
Polyurethane Foam (1 inches, open cell, reticulated)	.30
Rubber on concrete	.05
Seating (occupied)	.80 - .85

Seating (unoccupied), metal	.03
Seating (unoccupied), wood	.03
Seating (unoccupied), fabric upholstered	.60
Seating (unoccupied), leather upholstered	.50
Soundboard (1/2 inches thick)	.02
Sprayed cellulose Fiber (1 inches thick on concrete)	.50 - .75
Steel	.00 - .10
Terrazzo	.00
Wood	.05 - .15

Source:(Roit, 2009)

2.8 Behaviour of sound in a room

With the aim of investigating materials available locally to reduce sound in buildings by installing them on the walls of a room or using them as office partitioning materials, it is necessary to consider sound under the following conditions in a room.

In the circumstances where the source of sound is generated in a room to the wall the wave moves towards the wall in a spherical form where it is either absorbed, transmitted or reflected as indicated in Figure 2.2. The reflected sound moves to another wall where it is then absorbed, transmitted or reflected. This continues until its energy is completely absorbed or reflected. On the average it takes the reflection about 200 to 300 reflections before it is finally transmitted or absorbed (Watson, 1927). Reflection of sound is useful where the aim is to reduce the level of sound passing through the structure. The only disadvantage is where the source of sound is enclosed; most of the sound would be trapped in the enclosed area, thereby resulting in reverberation of sound. The enclosure properties strongly affect the sound in the enclosure (Bies and Hansen, 1988a).

2.9 Fundamentals of Acoustics

The following are some of the parameters of sound.

Frequency (Pitch)

Wavelength

Amplitude (Loudness)

Duration

The resonance can be analysed by using the following equation.

$$f_o = \frac{1}{2\pi} \sqrt{\frac{k}{m}} \quad 2$$

Where f_o is the operating frequency measured in hertz k is the stiffness of the material in Newton per meter m is the mass it is supporting

Another way to calculate the operating frequency is by using the equation

$$f_o = 4.98 \sqrt{d} \quad 3$$

(Bies et al., 2017) Where d is how much the isolating material is compressed in cm. f_o is the resonance frequency.

Transmissibility (T) equation of sound isolator is given as

$$T = \sqrt{\frac{1 + 2x^2}{1 + x^2 + 2x^2}} \quad 4$$

$$x = f/f_o \quad 5$$

(Bies et al., 2017)

Where

T is the transmissibility ζ is critical damping ratio f_o is the operating frequency f is the excitation frequency

2.10 Transmission loss and noise isolation

Noise level between a source and a worker, can be reduced by introducing an obstacle to its line of propagation. One expectation of the obstacle is to reduce noise entirely or completely from its origin but in reality, some of the noise may end up going through. Virtually that may depend on the reduction of the level of noise, the acoustic properties of the room and the properties of the reducing material. Transmission loss (TL) is defined as

$$TL = 10 \log_{10} \frac{1}{\tau}$$

6 Where

T_L is the Coefficient of transmission τ can be defined as the ratio of the sound transmitted to the incident energy on the obstacle.

The transmission loss is equal to the reduction, if the space receiving the sound is outdoor but the reduction noise can be determined by the equation below if the receiving space is indoors.

$$NR = TL + 10 \log_{10} \frac{A_{wall}}{s \bar{\alpha}}$$

7

(Bies and Hansen, 1988b)

Where

A_{wall} is the partition surface area $s \bar{\alpha}$ is the absorption of the receiving space in m^2

Porous materials allow the flow of sound through them as a result the pressure gradient, which determines its usefulness for acoustic purpose. An important property which is the flow resistance is defined as the induced pressure drop across the material over the resulting average volume velocity per unit area of the material and is given as

$$R_f = \frac{\Delta P}{U_0 A}$$

KNUST

8

(Bies and Hansen, 1988a)

Where

R_f is the flow resistance

ΔP is the pressure drop across the layer A

A is the Area of barrier

U_0 is the induced average volume flow in m^3/s

Experimental research indicates that porous materials normally made of uniform composition may be described by a unit flow resistivity. Meaning the flow resistivity (R_f) of such materials is directly proportional to the thickness (l) of the material given as,

$$R_f = R_1 l$$

9

(Bies and Hansen, 1988b)

Where

R_1 is a constant l

l is the thickness

2.11 Parameters for Evaluating Acoustic performance.

Flow Resistivity: Airflow measurement through a material is one of the physical properties used in assessing an absorbing acoustic material. The following useful equations are used to illustrate flow resistivity

$$R_f = \frac{\Delta P}{q_v} \quad 10$$

$$R_s = R_f A \quad 11$$

$$r_f = \frac{R}{d} \quad 12$$

(Kuczmarski and Johnston, 2011)

Where R_f is the flow resistance (Pa. s/m³)

ΔP is the pressure difference across the test sample (Pa) q_v

is the volumetric flow rate through the material (m³/s) R_s

is specific flow resistance (Pa.s/m)

A is cross-sectional area of the material perpendicular to the flow (m²)

r_f is flow resistivity (Pa·s/m²) d is the thickness of material (m)

2.11.1 Compression Rate (n)

Compression rate is given as $n = \frac{t_o}{t_n}$ 13

(Hosseini Fouladi et al., 2012)

Where t_o is original thickness of the sample t_n

is thickness of the sample after compression

2.12 Measurement and Duration

Time of measurements and duration at which measurements are taken may affect the noise levels that are measured. Measurements should be carried out over a sufficient

period of time to establish the average noise levels, and if necessary, maximum noise levels, from the facility.

The following equations are used to calculate the level of noise for day and night time

$$L_{AeqM} = 10 \log_{10} \left(\frac{1}{n} \sum_{i=1}^n L_{AeqA}^2 \right)$$

$$L_D = 10 \log_{10} \left(\frac{1}{n} \sum_{i=1}^n L_{AeqE}^2 + \frac{1}{n} \sum_{i=1}^n L_{AeqN}^2 \right) \quad (15)$$

$$L_D = 10 \log_{10} \left(\frac{1}{n} \sum_{i=1}^n L_{AeqE}^2 + \frac{1}{n} \sum_{i=1}^n L_{AeqN}^2 \right) \quad (14)$$

(Oyedepo and Saadu, 2010)

Where

L_{AeqM} = The equivalent sound pressure for the morning measurement

L_{Aeq} = The A-weighted equivalent sound pressure level

L_{AeqE} = The equivalent sound pressure level for the evening measurement

L_{AeqA} = The equivalent sound pressure level for the afternoon measurement

L_{AeqN} = The equivalent sound pressure level for the night measurement

L_N = Night time noise level

L_D = Day time noise level

CHAPTER THREE

MATERIALS AND METHODS

This chapter describes the procedures for the following activities: collection of the local materials, performing sieve analysis to determine the particles sizes of the local wastes, fabrication of mould, preparation of the binder, forming of the tiles, and carrying out the experiments to obtain data.

Local materials identified and considered. Preparation of binding agent, forming of the test samples, experiments were carried out using the samples in an impedance tube to study its sound reduction effects to collect data.

The mode of collecting and transporting the material was by means of vehicle to the laboratory. The Sawdust, mainly Red Wood collected from the Sokoban wood village and the coconut fiber from the Suame Runabout Market, Kumasi. The Starch and the Vinegar, as well as the carpenter's glue used as binding agent was obtained from the Central Market, Kumasi.

In the laboratory, sieve analysis of the material particle into grades, was carried out using sieves sizes of 4.75, 2.00 and 0.6 mm. The different grades of grains was used to prepare tiles blended with brown coconut fiber in a given ratio.

A mould of specified diameter size was prepared at the carpentry shop was used to form the tiles using the universal hydraulic tensile testing machine to compress the prepared samples. The maximum capacity of the universal hydraulic compressing machine is 50 ton. Samples formed from these materials were used to carry out the experiment after which the data collected was analysed.

Necessary conclusions drawn after the study and a sound reduction material proposed.

3.1 Preparation of Mould

A cylindrical Mould made of galvanized steel pipe with an internal diameter of 75 millimeters and thickness 3 millimeters was used to form the shape of the sample. The galvanized steel pipe, base plate and the piston used to form the samples are shown in Figure 3.1

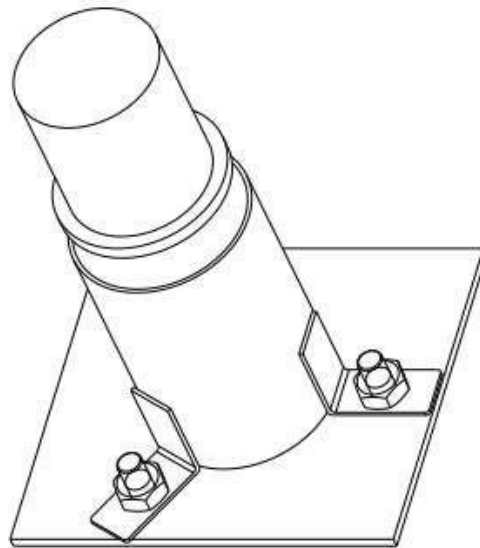

KNUST (Dept. of Mech. Eng)				
TITLE				
Mould				
SIZE	CAGE CODE	DWG NO	REV	
C	001	001	1	
SCALE: 1	UNIT BY: mmE_23 kg		SHEET 1 OF 6	

Figure 3.1 The mould used to form the test samples

3.2 Instrumentation

3.2.1 Precision Digital sound level meter (DT8852)

The sound level meter used in measuring the sound level during the experiment was a DT8852 precision Digital meter with a data logger. It was calibrated as specified by the manufacturer before taking readings at the beginning of each test on daily basis. It is designed for all kinds of environmental sound measurement. The unit dBA is the

average measure of the noise level. The Precision Digital Sound Level Meter has the following specifications:

Table 3.1 Instrument Specifications:

Applied Standard	IEC61672-1 Class 2
Accuracy	± 1.4 dB
Frequency range	3.15 Hz – 8 kHz
Microphone	$\frac{1}{2}$ inch electric condenser microphone
Analog output	$\frac{AC}{DC}$ output, AC= 1Vrms, DC=10 mV/dB
Data logger: Sampling time rate	1 – 59

3.2.2 Balance Scale

A balance scale was used to weigh the raw materials. The balance scale was calibrated each day before the beginning of each sample preparation using a digital weighing scale.

3.3 Binder Preparation

Originally, the idea was to use only Cassava starch prepared locally but after a few tests, it was observed that it could not give a proper binding of the particles, so this idea was abandoned.

It was found from other research works that a combination of Cassava starch and vinegar gives a better binding. Cassava starch and vinegar prepared at the laboratory was used as a binding agent for the research. Cassava Starch and vinegar used in preparing the binder were obtained from the Kumasi central market, Ghana.

Starch of mass 0.4536 kilogram was weighed using a balance scale. The starch was then mixed with 650 milliliters of water and 40 milliliters of vinegar. The mixture was

put in an aluminum-cooking utensil and prepared by cooking it for about seven (7) minutes, after which the binder was ready to be used. The starch and the vinegar prepared gave a better binding but could not exhibit the right properties needed. The test sample became very hard after allowing it to dry under room temperature, therefore carpenters white glue and silicone were rather used.

3.5 Extraction of Fibers

Sawdust and Coconut fibers were used as the main raw materials. Saw dust is usually thrown away as a waste by-product at the sawmills. The natural fiber extracted from the outer shell of the mature coconut fruit was used. There are different types of this waste product, white and brown, but the brown fiber was chosen above the white because it is more available than the white fiber.

During preparation, the fiber was extracted manually from the fruit and left to dry in the sun. It was then carried to the grinding machine where the coconut fiber was milled into smaller particles.

3.6 Sieve Analysis

Sawdust collected from the Sokoban wood village was sieved into three particles sizes. The sieves used were a 4.7 mm, a 2.0 mm and a 0.6 mm sieves. The sieves were arranged in such a way that, the 4.7 millimeters (mm) sieve was on top, followed by the 2.0 millimeters (mm) and with 0.6 millimeters underneath. The Sawdust particles passing through 4.7 millimeters (mm) but retained on the 2.0 millimeters sieve i.e. $(4.7 > x \geq 2.0)$ millimeters and that passing through 2.0 millimeters i.e. $(2.0 > x)$, were obtained and used to develop the acoustic materials. Further sieving analysis were done on these local materials to achieve very fine particle size using a sieve size of 0.6 millimeters.

Figure 3.2 to 3.3 show photograph of particle distributions after sieving the sawdust, coconut fiber and the expansive clay.

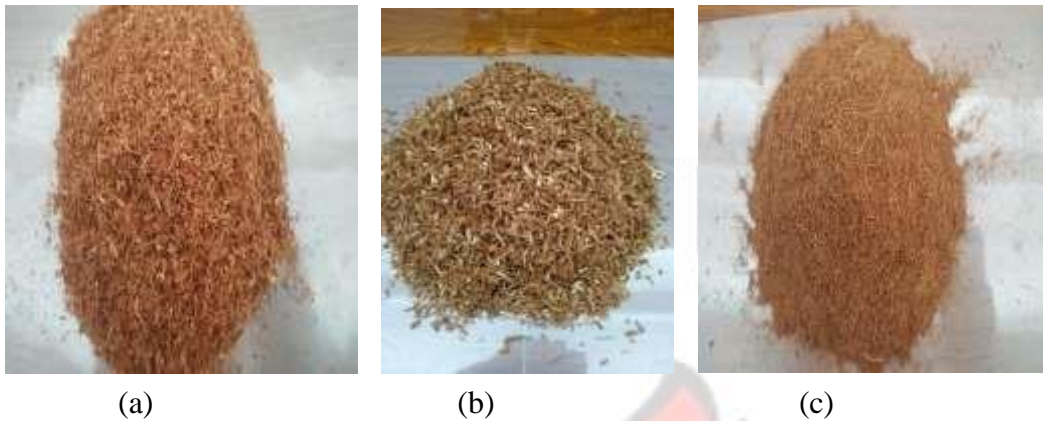

Figure 3.2 Photograph of the samples after sieving



Figure 3.3 Photograph of the samples after sieving.

Table 3.2 Particles distribution and Classification samples after sieving

Particles distribution	Classification
Particle sizes of the range $4.7 > x \geq 2.0$	big grade
Particles sizes of range $2.0 > x$ mm	small grade
particles sizes less than 0.6 mm	fine grade
Coconut Fiber less than 0.6 mm	fine grade
Expansive clay less than 0.6 mm	fine grade
Coconut Fiber	un-sieved

3.7 Compression of Samples

Table 3.2 shows the mixed proportions of the materials used to develop the samples

Proportions of materials used to develop the samples

Table 3.3 Mixture of Different Grade of Materials

Sample number	Thickness of sample (mm)	Proportions on weight basis					
		Coconut Fiber	Small grade sawdust	Big grade Sawdust	Clay	Binder	Fine grade sawdust
1	30.6	-	1	-	-	2	-
2	33.6	-	1	-	-	2	-
3	31.5	1	1	-	-	2	-
4	30.1	1	1	1	-	2	-
5	31.0	-	1	1	-	2	-
6	20.0	1	-	-	-	2	-
7	30.3	-	-	-	-	2	1
8	30.4	1	-	-	-	2	1
9	23.0	-	-	-	1	2	1

The compression of the samples for the test was done using hydraulic means. Figure 3.7 shows a 50-ton capacity hydraulic tensile testing machine used in compressing the samples prepared. The prepared samples were compressed and weighed. Small grade and big grade sawdust samples were compressed up to 3.5 tons at room temperature. Fine grade sawdust samples were compressed up to 5 tons at room temperature. A layer of 2.5 millimeters (mm) of dry plantain leaves was inserted halfway into some of the samples before further compression. Compression was performed under ambient temperature.

Figures 3.8, to 3.14 show the test samples developed after the compression with different grades of sawdust. This includes small grade, big grade, small and big grades mixed together, and small as well as big grades mixed with coconut fiber.



(a)



(b)

Figure 3.4 Small grade sawdust ((a) with dry plantain leaf layer and (b) without dry plantain leaf layer)

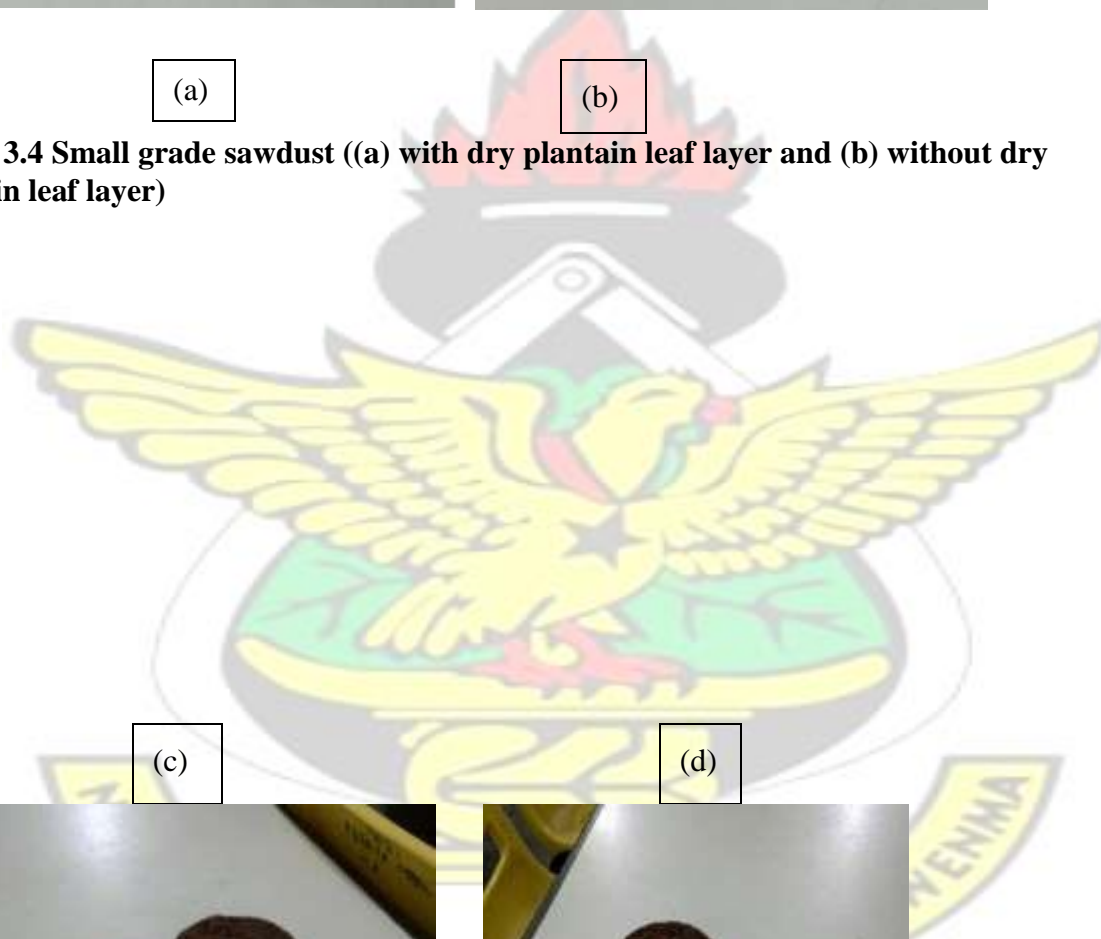

(c)



(d)



Figure 3.5 Mixture of small and big grade sawdust ((c) with dry plantain leaf layer and (d) without dry plantain leaf layer)

Figure 3.6 Mixture of small grade sawdust and coconut fiber ((e) with dry plantain leaf layer and (f) without dry plantain leaf layer)

Figure 3.7 big grade sawdust ((g) with dry plantain leaf layer with and (h) without dry plantain leaf layer)

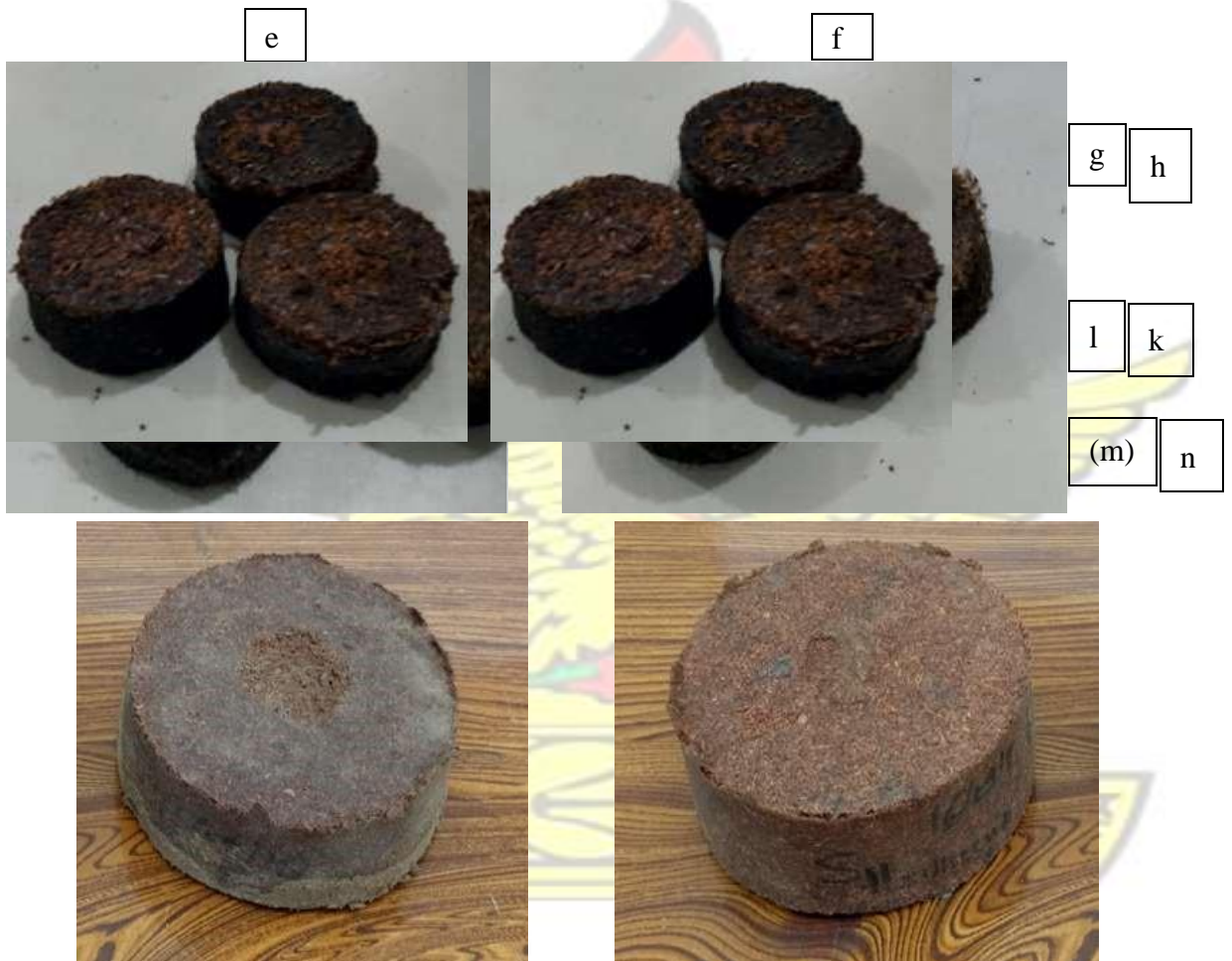

Figure 3.8 Fine grade sawdust ((k) with expansive clay and (l) without expansive clay)



Figure 3.9 (m) Coconut fiber mixed with Expansive clay and (n) Coconut fiber mixed with fine grade sawdust.



Figure 3.10 Samples made with plantain leaf Layer

3.8 Experimental Setup

An experimental setup was prepared for the test. The set-up was in a form of an impedance tube with sample holder. It consist of a precision digital sound level meter (DT8852), a speaker inserted at one end, an hp laptop to log the data recorded by the sound level meter and a DEGEM SYSTEMS (TK/FG) signal generator (model141B1), with a frequency range of 1 Hz - 1 M Hertz (MHz). The signal generator was used to

generate the sound at different frequencies for the experiment. The selected frequencies used to investigate the noise level ranges from 1-8 kHz. The level of the sound intensity measured in decibels (dBA), before and after placing the sample acoustic materials at the selected frequency was measured using the sound meter. The precision digital sound level meter was inserted into the tube and connected to the hp laptop as shown in the Figure 3.16 to log the data.

In order to minimize the effect of the noise in the background on the measurements, experiments were conducted during weekends, from 4:30 am to 10.00 am.

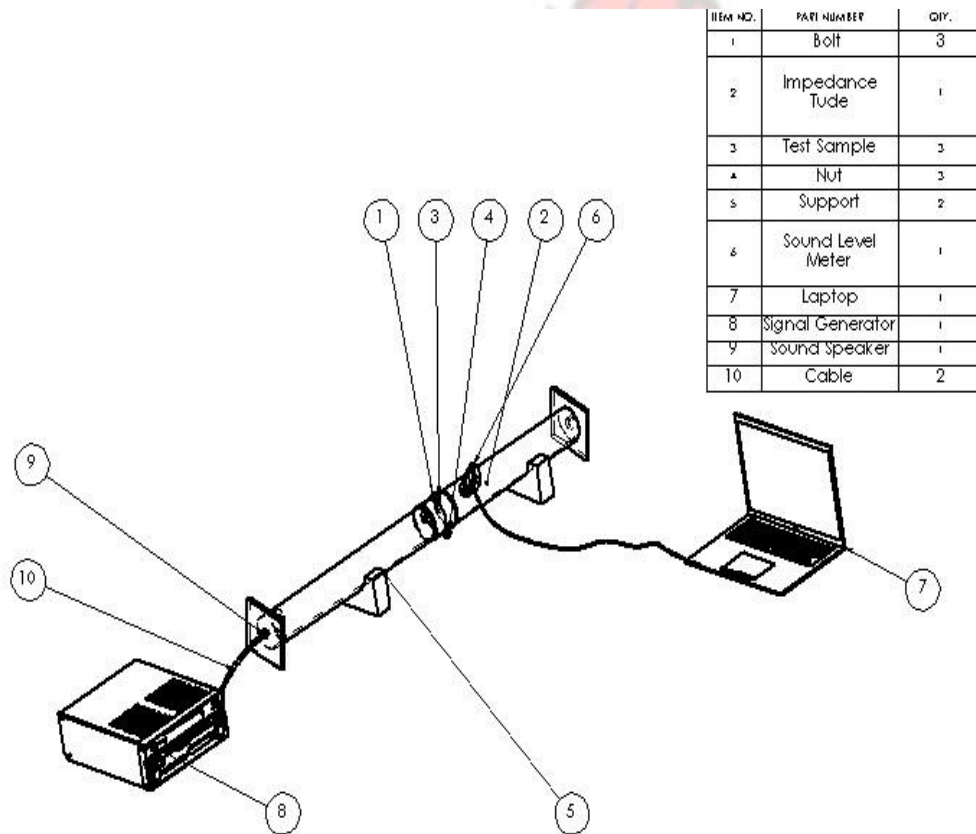

Figure 3.11 Experimental setup of the Impedance Tube

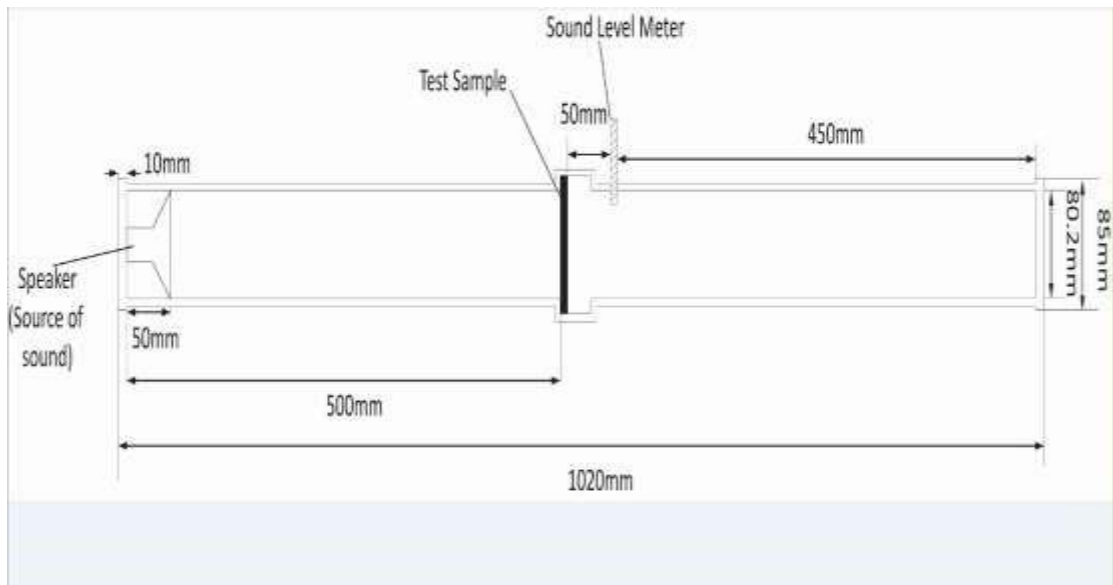

Figure 3.12 Experimental setup of the Impedance Tube

Before the sound proofing samples were used, measurements of sound levels were taken at different signal generator frequencies. This was done for the frequency range

1-8 kHz inclusive, at an interval of 0.5 kHz. The sound reduction materials were then fitted into the sample holder and the measurement of the intensity of the sound level was recorded for the same frequency ranges at the same intervals.

Sound Reduction and Absorption Coefficients were then determined according to the ASTM E-1050 standard in the laboratory using the measured data.

The Noise Reduction Coefficient (NRC) is the means used to determine the effectiveness of the noise reduction of the material at different frequencies.

$$\text{Noise Reduction Coefficient (NRC)} = \frac{a-b}{a} \quad 3.1$$

$$\text{Noise Absorption Coefficient (NAC)} = \frac{b}{a} \quad 3.2$$

Where, **a** is sound intensity measurement in decibel (dBA) without placing the acoustic material and **b** is measurement of the sound intensity in decibel (dBA) with the acoustic material in place.

In the current study, Noise Reduction Coefficient (NRC) was used to quantify the effect of noise reduction at each frequency. Noise Reduction Coefficient (NRC) was determined as the ratio of the noise reductions due to the specimen to the incident noise level without placing the specimen. Equation 3.1 was used to calculate the NRC values for the tests



CHAPTER FOUR

RESULTS AND DISCUSSION

This chapter presents the obtained experimental data and the analysis of the data that enabled the computation of the Noise Reduction Coefficient (NRC) for different materials, particles sizes and different mixed proportions of the tested materials.

OBJECTIVE 1: To investigate the noise level within some specific frequency range.

Table 4.1 shows the experimental values of the noise level within some specific frequency range without the test sample developed in place. It contains the selected frequency range of 1 to 8 kHz. The measurements of the sound level without the test sample developed in place continuously recorded at 0.5 kHz intervals. The sound levels at the given frequency was obtained in decibels (dBA) before placing the test materials developed at the start of each experiment.

Observation from the table indicated that day 1, recorded maximum sound level value of 99.8 dBA at the frequency 3.5 kHz and its minimum value of 89.7 dBA at the frequency 5.0 kHz. Day 2 registered its maximum noise level value of 84.7 dBA at the following frequencies 1.5, 2.0 and 3.5 kHz with its lowest sound level of 83.9 dBA at 1 kHz. The maximum noise level for day 3 recorded its peak value of 98.8 dBA at the frequency of 4.0 kHz with its minimum value of 70.4 dBA occurring at 8.0 kHz.

Table 4.1 Noise level within a specific frequency range

Frequency (kHz)	Sound level without test sample (dBA) Day 1	Sound level without test sample (dBA) Day 2	Sound level without test sample (dBA) Day 3
1.0	96.4	83.9	97.6

1.5	97.2	84.7	96.0
2.0	99.5	84.7	95.0
2.5	99.4	84.5	86.3
3.0	98.7	84.5	85.0
3.5	99.8	84.7	88.6
4.0	98.7	84.5	98.8
4.5	99.2	84.3	84.3
5.0	89.7	84.5	82.1
5.5	97.1	84.5	82.9
6.0	90.8	84.3	86.2
6.5	95.7	84.3	86.7
7.0	92.4	84.3	73.4
7.5	97.7	84.3	80.6
8.0	94.9	84.3	70.4

OBJECTIVE 2: Determination of sound level using various types of materials

Table 4.2 to 4.4 shows the sound reduction level of the various type of test materials developed in place within the given frequency range of 1 kHz to 8 kHz.

Table 4.2 show the sound levels of small grade sawdust with and without a layer, mixture of small grade, big grade sawdust, with and without a layer of dry plantain leaves in decibels.

The results show that small grade sawdust without a layer prevented most of the sound from passing through while the test sample with a layer was not able to prevent most of the sound from passing through it. The sample without a layer recorded its maximum value of 68.8 dBA at the frequency 2 kHz while the test sample with a layer recorded its maximum value of 90.0 dBA at the frequency of 1 kHz.

For the test samples developed from the mixture of small grade and big grade sawdust, the test sample without a layer registered its maximum value of 91.1 dBA at the frequency of 1 kHz with its minimum value of 60.7 dBA at the frequency of 6.5 kHz.

The sample with a layer recorded a maximum value of 92.0 dBA at the frequency 2.0 kHz and its minimum value of 57.7 dBA at the frequency 3.5 kHz.

Table 4.2 Sound level of the various materials.

Frequency (kHz)	Small grade sawdust without a layer of dry plantain leaves (dBA)	Small grade sawdust with a layer of plantain leaves (dBA)	A mixture of small and big grade sawdust without a layer dry plantain leaves (dBA)	A mixture of small and big grade sawdust with a layer dry plantain leaves (dBA)
1.0	67.2	90.0	91.1	89.4
1.5	63.8	88.6	82.5	74.5
2.0	68.8	84.7	87.0	92.0
2.5	63.9	73.6	85.9	74.6
3.0	64.8	64.7	75.6	70.6
3.5	59.5	79.8	86.1	57.7
4.0	62.8	71.4	82.5	75.7
4.5	58.4	62.4	70.1	63.6
5.0	67.4	79.6	81.8	68.7
5.5	64.2	64.6	79.4	59.7
6.0	60.1	68.7	70.7	62.0
6.5	58.7	70.9	61.7	63.1
7.0	50.7	61.6	70.2	72.5
7.5	60.2	66.2	66.6	56.8
8.0	51.7	60.2	63.0	52.2

Table 4.3 shows the sound level of the various materials of big grade sawdust with and without a layer and a mixture of small grade, big grade and a mixture of small grade, big grade sawdust with coconut fiber.

The sound level of the big grade sawdust without a layer has a maximum sound level of 90.0 dBA at the frequency 1 kHz with its minimum value of 60.2 dBA occurring at the frequency of 8 kHz. The big grade test sample with a layer recorded its maximum value of 99.9 dBA occurring at the frequency 3.5 kHz with its lowest value 71.6 dBA occurring at 7.5 kHz.

Test sample produced from a mixture of the two grades sawdust, small and big recorded its peak value of 92.0 dBA at the frequency of 2.0 kHz with its lowest value of 52.2 dBA at the frequency of 8 kHz.

Combinations of small grade, big grade and coconut fiber recorded a maximum value of 84.1 dBA at the frequency of 1 kHz while its minimum value of 54.3 dBA registered at the frequency of 4.0 kHz.

Table 4.3 Sound level of the various materials.

Frequency (kHz)	Big grade sawdust (dBA)	Big grade with a layer of dry plantain leaves (dBA)	A mixture of small and big grade sawdust with a layer dry plantain leaves (dBA)	mixture of small grade, big grade and coconut fiber (dBA)
1.0	90.0	99.5	89.4	84.1
1.5	88.6	98.9	74.5	77.6
2.0	84.7	99.1	92.0	80.0
2.5	73.6	97.5	74.6	70.5
3.0	64.7	91.1	70.6	66.1
3.5	79.8	99.9	57.7	74.1
4.0	71.4	93.3	75.7	54.3
4.5	62.4	90.4	63.6	64.9
5.0	79.6	90.5	68.7	74.7
5.5	64.6	94.3	59.7	54.9
6.0	68.7	92.1	62.0	68.3
6.5	70.9	82.9	63.1	71.5
7.0	61.6	88.2	72.5	71.6
7.5	66.2	71.6	56.8	60.2
8.0	60.2	83.4	52.2	58.2

Table 4.4 show the sound level of the various test materials developed using fine grade sawdust, fine grade coconut fiber, mixtures of fine grade sawdust and fine grade coconut fiber, fine grade sawdust mixed with expansive clay and a mixture of fine grade coconut fiber mixed with expansive clay.

Fine grade sawdust recorded its peak sound level of 57.5 dBA at the frequency of 5.5 kHz with its lowest value of 39.9 dBA at the frequency 6.5 kHz. Fine grade coconut fiber registered its maximum sound level of 76.9 dBA at the frequency 1.5 kHz. Fine grade sawdust mixed with coconut fiber has a peak value of 59.2 dBA at the frequency 1 kHz while its minimum value of 40.1 dBA recorded at 7.5 kHz. Test sample

developed from the mixtures of fine grade sawdust with expansive clay recorded its maximum sound level value of 58.1dBA at 1 kHz frequency with its minimum value of 34.6 dBA at the frequency of 8.0 kHz.

Sound level of coconut fiber mixed with expansive clay recorded its maximum value of 59.6 dBA at the frequency of 2.5 kHz with its minimum value of 36.3 dBA at the frequency of 6.0 kHz.

Table 4.4 Sound level of the various materials.

Frequency (kHz)	Fine grade sawdust (dBA)	Fine grade coconut fiber (dBA)	Fine grade Sawdust mixed with Coconut fiber (dBA)	Fine grade sawdust mixed with expansive clay (dBA)	Coconut fiber mixed with expansive clay (dBA)
1.0	53.4	68.1	59.2	58.1	56.6
1.5	48.9	76.9	53.9	48.4	48.9
2.0	51.0	73.7	53.6	52.6	49.6
2.5	47.6	60.5	57.2	53.0	59.6
3.0	55.8	69.8	58.5	47.4	56.9
3.5	52.1	68.7	47.0	39.6	45.3
4.0	46.0	56.1	58.5	37.8	54.0
4.5	43.0	54.1	54.4	42.3	40.2
5.0	49.4	44.7	56.4	40.4	50.4
5.5	57.5	62.4	56.1	54.0	45.9
6.0	47.2	70.9	49.9	51.1	36.3
6.5	39.9	65.2	44.2	43.4	36.8
7.0	43.5	55.5	45.0	55.5	43.8
7.5	47.8	62.2	40.1	38.2	38.6
8.0	40.5	58.8	41.4	34.6	41.5

OBJECTIVE 3: Comparison of NRC for the various types of materials used.

Table 4.5 shows the calculated values of noise reduction coefficient of the various types of materials used.

Table 4.5 Calculated values of noise reduction coefficients

Small grade sawdust without a layer of dry plantain leaves	Small grade sawdust with a layer of dry plantain leaves	Mixture of small and big grade sawdust without a layer of dry plantain leaves	Mixture of small and big grade sawdust with a layer of dry plantain leaves	Small grade sawdust without a layer of dry plantain leaves	Big grade sawdust
0.30	0.07	0.05	0.07	0.08	0.07
0.34	0.09	0.15	0.23	0.08	0.09
0.31	0.15	0.13	0.08	0.11	0.15
0.36	0.26	0.14	0.25	0.05	0.26
0.34	0.34	0.23	0.29	0.24	0.34
0.40	0.20	0.14	0.43	0.1	0.20
0.36	0.28	0.16	0.23	0.28	0.28
0.41	0.37	0.29	0.36	0.26	0.37
0.25	0.11	0.09	0.23	0.03	0.11
0.34	0.33	0.18	0.39	0.22	0.33
0.34	0.24	0.23	0.32	0.2	0.24
0.39	0.26	0.36	0.34	0.18	0.26
0.45	0.33	0.24	0.22	0.16	0.33
0.38	0.17	0.32	0.42	0.17	0.32
0.46	0.14	0.34	0.42	0.14	0.37

Figure 4.1 shows the Noise Reduction Coefficient (NRC) of the sawdust with and without a layer of dry plantain leaf at the frequency ranges of 1000 hertz to 8000 hertz. From the graph, the results show that sawdust without the layer performed far better than sawdust with a layer in terms of Noise Reduction Coefficient (NRC). The results from the graph clearly show that sawdust without a layer has the lowest reduction value of 0.25 representing 25% at the frequency of 5 kHz and the highest NRC value of 0.45 representing 45% at the frequency ranges 7 - 8 kHz. It shows better performance in the reduction within the frequency range of 1 kHz to 4.5 kHz and frequency greater than 5 kHz to 8 kHz. Clearly, a reduction of the NRC between the frequency of 4.5 kHz and 5 kHz could also be observed.

Similarly, the NRC of the sample with the layer performed lower, with the least value of 0.04 at the frequency of 5 kHz and the maximum value of 0.28 at the frequency of 4 kHz. Generally, the sample without a layer performed better having higher NRC values than the sample with the layer. Both samples exhibited lower NRC at the frequency of 5 kHz.

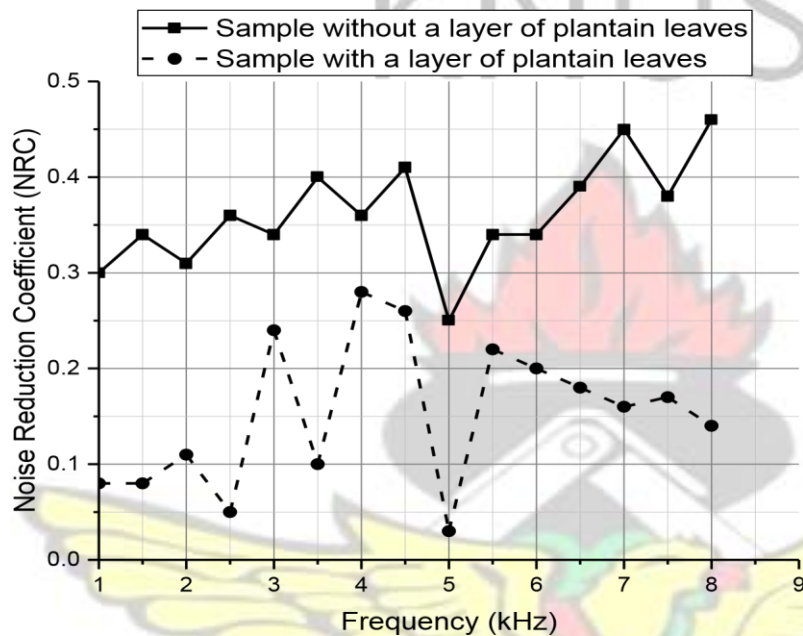

Figure 4.1 Noise Reduction Coefficients for small grade Sawdust at different frequencies

Figure 4.2 shows the Noise Reduction Coefficient (NRC) of a mixture of the big grade and the small grade sawdust. Results show that sample with a layer gained higher values than the sample without a layer, except at 2 and 7 kHz. At 2 kHz, it registered a noise reduction of 0.075 (7.5%) and 0.225 (22.5%). The sample with a layer gained its peak value of 0.43 at a frequency of 3.5 kHz, while the sample without a layer recorded its peak value of 0.363 (36.3%) at 6.5 kHz and lowest noise reduction coefficient value of 0.05 (5%) at a frequency of 1 kHz. Generally, the noise reduction coefficient for the mixture of the small grade and big grade sawdust with a layer gained higher values than one without the layer.

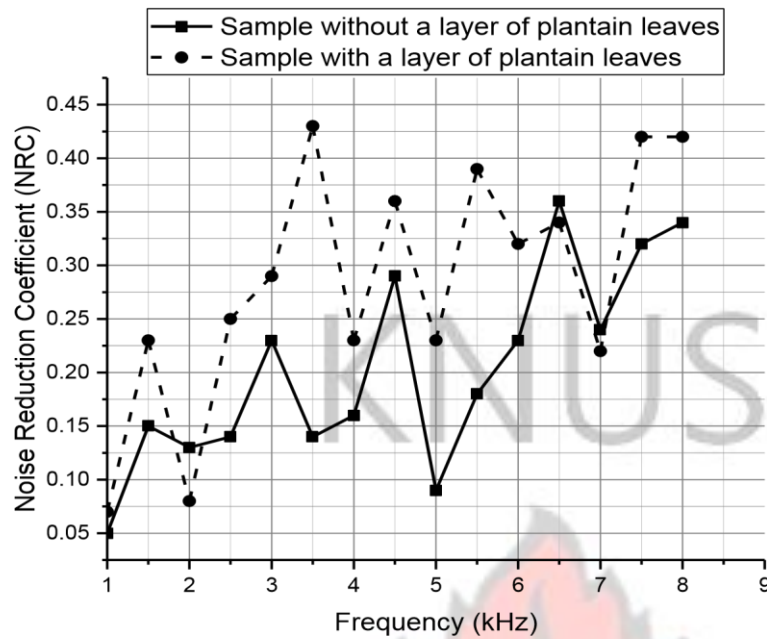

Figure 4.2 Noise Reduction Coefficient of a mixture of small and big grade sawdust at different frequencies.

Figure 4.3 clearly show the performance of the NRC between the big grade and the small grade. The performance of the small grade gained higher values than the big grade except at a frequency of 7.5 kHz where it recorded its peak value of close to 0.275 (27.5%). Significantly, the sample with small grade sawdust recorded its peak NRC at the frequency of 4 kHz with a reduction of 0.28 (28%) and its minimum NRC value of 0.025 (2.5%). The big grade recorded its minimum NRC value of 0.025 (2.5%) at the frequency of 5 kHz.

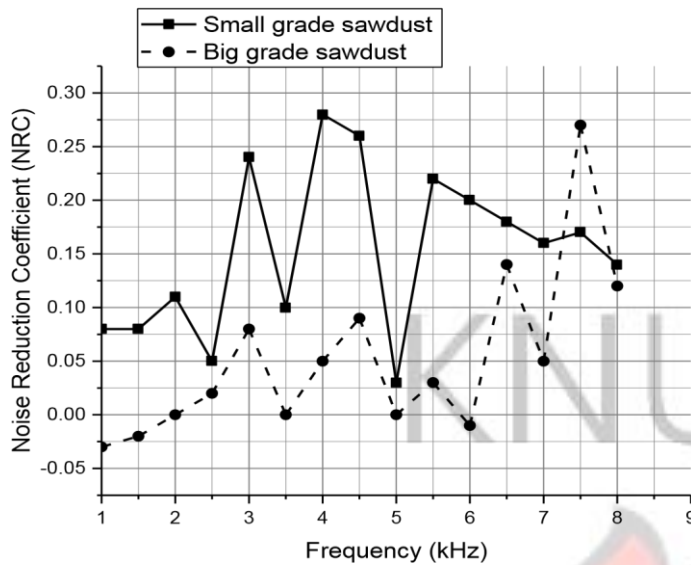

Figure 4.3 Effect of the particle size on Noise Reduction Coefficient at different frequencies.

Table 4.6 calculated values of noise reduction coefficients.

Small grade sawdust	Big grade sawdust	Mixture of small grade, big grade and coconut fiber	Sample with fine grade sawdust	Sample with fine grade sawdust mixed with Coconut fiber
0.30	0.07	0.13	0.45	0.39
0.34	0.09	0.20	0.49	0.44
0.31	0.15	0.20	0.46	0.44
0.36	0.26	0.29	0.45	0.34
0.34	0.34	0.33	0.34	0.31
0.40	0.20	0.26	0.41	0.47
0.36	0.28	0.45	0.53	0.41
0.34	0.37	0.35	0.49	0.35
0.25	0.11	0.17	0.40	0.31
0.34	0.33	0.43	0.31	0.32
0.34	0.24	0.25	0.45	0.42
0.39	0.26	0.25	0.54	0.49
0.45	0.33	0.23	0.41	0.39
0.38	0.32	0.38	0.41	0.50
0.46	0.37	0.39	0.42	0.41

Figure 4.4 shows a comparison of NRC of three different sample materials. The three are the small grade sawdust, big grade sawdust and a mixture of coconut fiber, small grade and big grade sawdust. The results clearly show that the combination of the small

grade sawdust, big grade sawdust and coconut fiber with the binder combined in the mass ratio of 1:1:1:2 performed better than the small grade sawdust. Its peak NRC value of 0.45 (45%) was recorded at the frequency of 3.5 kHz and its minimum NRC of 0.14 at the frequency 1 kHz. The results also show that the big grade sawdust is more porous and therefore the performance with reference to noise reduction is very low compared to the small grade and the combination to the three materials as illustrated on the graph. That is, the bigger the particle size the lower the performance in relation to noise reduction.

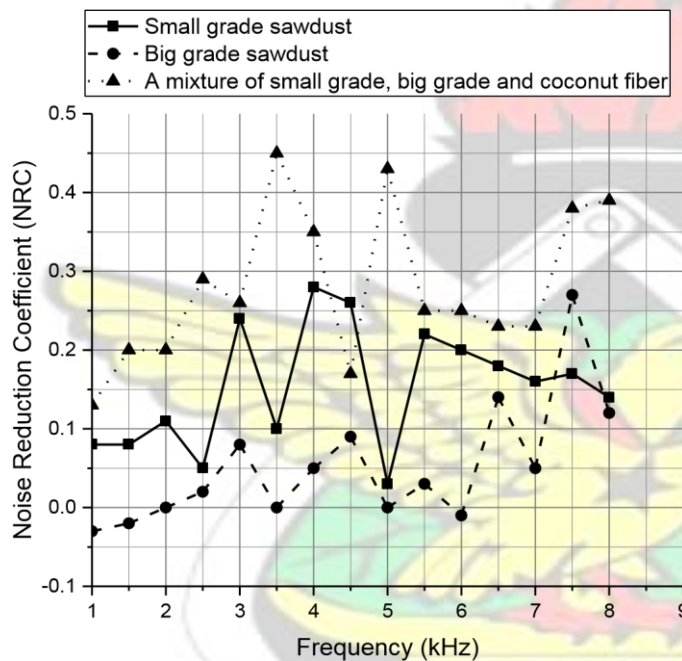

Figure 4.4 Noise Reduction Coefficient for different samples at different frequencies.

Figure.4.5 shows the performance of the Noise Reduction Coefficient of fine grade sawdust with and without coconut fiber. Fine grade sawdust are sawdust particles that passes through a 0.6 mm – sieve. The coconut fiber was sieved with the same sieve. The mixed proportion of the Sawdust, Coconut Fiber and the binder had a mass ratio of 1:1:2. It was compressed to 3.5 tons. The result clearly indicated that the fine grade sawdust without coconut fiber recorded higher NRC values than that mixed with

coconut fiber. The fine grade sawdust recorded its peak NRC value of 0.54 (54%) at the frequency of 6.5 kHz while that mixed with the Coconut fiber registered its maximum reduction value of 0.50 (50%) at the frequency 7.5 kHz. Both samples show least reduction of 0.31 or 31% NRC.

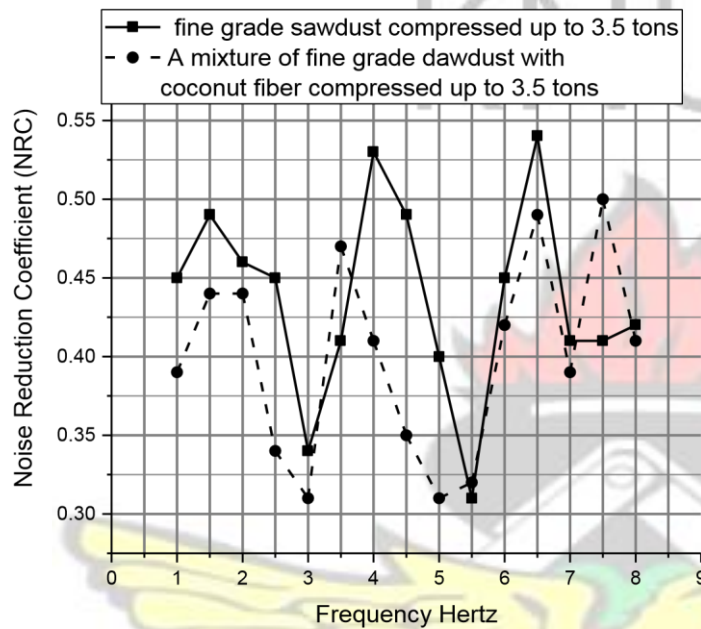

Figure 4.5 Noise Reduction Coefficient of fine grade sawdust with and without coconut fiber at different frequencies

Table 4.7 Calculated values of noise reduction coefficients

Fine grade sawdust	Coconut fiber	Mixture of fine grade sawdust with Coconut fiber	Fine grade sawdust mixed with expansive clay	Coconut fiber mixed with expansive clay
0.32	0.18	0.19	0.4	0.42
0.32	0.09	0.17	0.5	0.49
0.25	0.13	0.1	0.45	0.48
0.22	0.28	0.36	0.39	0.31
0.27	0.17	0.23	0.44	0.33
0.37	0.19	0.33	0.55	0.49
0.35	0.34	0.44	0.62	0.46
0.44	0.36	0.53	0.5	0.52
0.43	0.47	0.52	0.51	0.39

0.32	0.26	0.45	0.35	0.45
0.29	0.16	0.23	0.41	0.58
0.33	0.23	0.37	0.5	0.58
0.37	0.34	0.34	0.24	0.4
0.38	0.26	0.37	0.53	0.52
0.42	0.30	0.46	0.51	0.41

Figure 4.6 shows the noise reduction coefficient of fine grade sawdust, coconut fiber, and a mixture of fine grade sawdust and coconut fiber each compressed up to 5 tons, unlike the previous samples considered, that were all compressed up to 3.5 tons. The results show that the most effective noise reduction material, in this case, to be the material developed from the combination of the Sawdust and the Coconut Fiber. The noise reduction coefficient for the mixture of coconut fiber and sawdust reached the maximum value of 0.53 (53%) at the frequency of 4.5 kHz. The least performed material as far as noise reduction is concerned is the coconut fiber, but it recorded its reduction values higher than that of the sawdust at the frequencies 2.5 kHz and 5 kHz with NRC values of 0.28 and 0.47 respectively. Generally, the fine grade performed better than the coconut fiber in almost all the frequencies except at the 2.5 and 5.0 kHz. The result from Figure 4.5 and Figure 4.6 confirmed a paper published by Bernard Castagnede et al. (2000). It shows that when a material of the same properties are compressed to different forces without changing the properties of the material, it only reduces in thickness. The material with reduced thickness ended up transmitting more sound through.

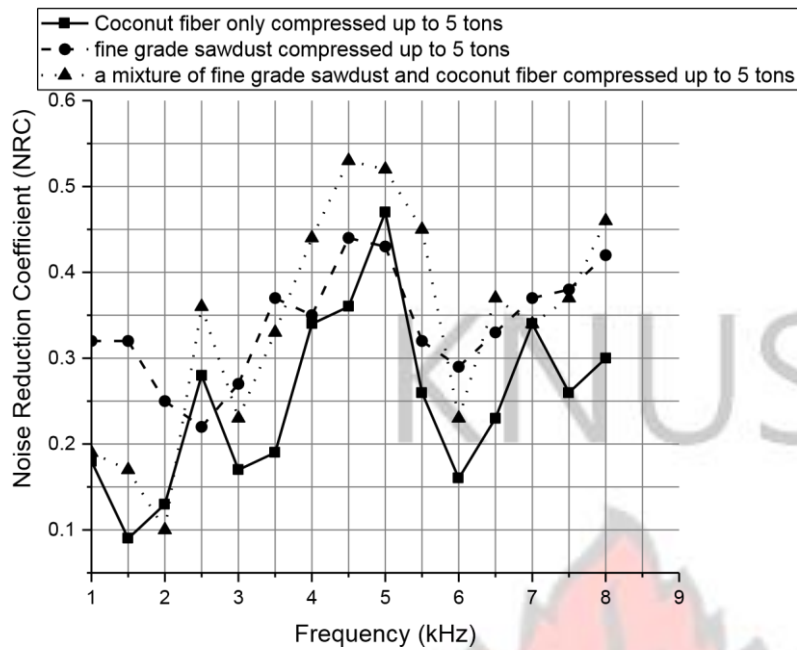

Figure 4.6 Noise reduction coefficient of coconut fiber and fine grade sawdust compressed to 5 tons

Figure 4.7 shows the Noise Reduction Coefficient (NRC) for samples developed from the mixture of sawdust, and expansive clay, and a mixture of coconut fiber and expansive clay. Observation from the graph indicated there is a better performance in the Noise Reduction Coefficient with both samples developed by mixing with the Expansive Clay. The sample developed with Sawdust and the Expansive Clay recorded its maximum NRC value of 0.62 (62%) at frequency of 4 kHz and its minimum value of 0.24 (24%) at frequency of 7 kHz. On the other hand the Coconut Fiber mixed with the Expansive Clay recorded its peak values of 0.58 (58%) at 6 and 6.5 kHz and its minimum value of 0.31 (31%) was recorded at the frequency of 2.5 kHz.

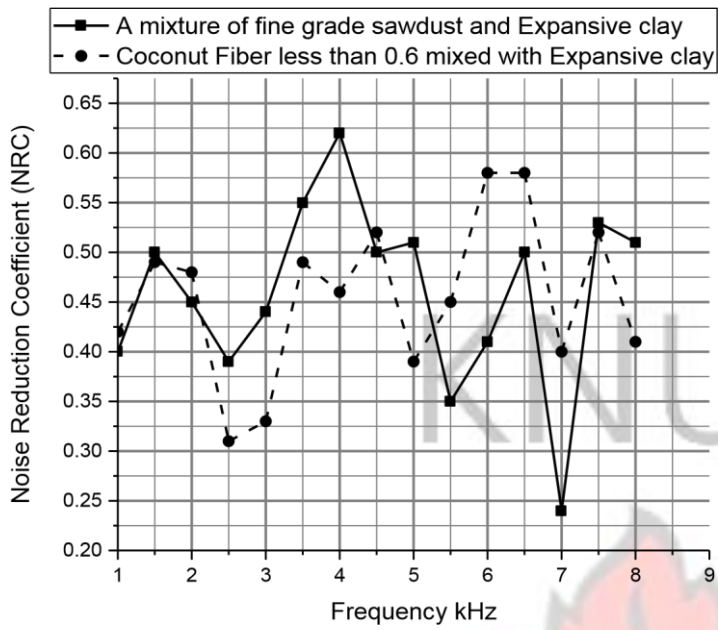

Figure 4.7 Noise Reduction Coefficient of samples made with mixtures of Expansive Clay and fine grade sawdust, and with Coconut fiber.



CHAPTER FIVE

CONCLUSION AND RECOMMENDATION

5.1 Conclusion

This research investigated the Noise Reduction Coefficient (NRC) of samples developed with sawdust, coconut fiber, expansive clay and dry plantain leaf. The results showed that NRC improved by reducing the particle size and increasing the thickness of the test sample. The samples developed using small grade have a good noise reduction coefficient. For the material developed from sawdust and expansion clay, NRC values varied between 0.24 - 0.62 with the maximum value (0.62) occurring at 0.4 kHz frequency.

NRC values of coconut fiber mixed with expansive clay varied between 0.31 - 0.58 with the maximum value of (0.58) occurring at 0.4 kHz frequency.

It was also found that sawdust, coconut fiber and expansive clay, which are natural materials, have good acoustic properties and therefore may be used as alternatives to produce acoustic board panels or tiles with appreciable noise reduction properties. Making use of these materials which otherwise are waste products will reduce environmental pollution.

5.2 Recommendation

It is recommended that, further investigation be carried out on the binding agent, durability and strength of the product.

REFERENCES

Abd-elfattah, A.M and Abd-Elbasseer, M., 2011. Characterization of poly-isoprene

rubber layer backed with porous material as sound absorber and vibration damper. J. Am. Sci. 7.

Asdrubali, Francesco. (2007). "Evaluation of the Acoustic Properties of Materials Made from Recycled Tyre Granules." https://www.researchgate.net/profile/Francesco_Asdrubali/publication/258226698_Evaluation_of_the_acoustic_properties_of_materials_made_from_recycled_tyre_granules/links/00b495277954bc0264000000/Evaluation-of-the-acoustic-properties-of-materials-made-from-recycled-tyre-granules.pdf?origin=publication_detail. (Accessed: May 12, 2018)

Bies, D., Hansen, C., Howard, C., 2017. Engineering Noise Control, Fifth Edition. Taylor & Francis, Abingdon, UK.

Bies, D.A., Hansen, C.H., 1988a. Engineering Noise Control: Theory and Practice. Taylor & Francis, Abingdon, UK. <https://doi.org/10.4324/9780203163900> (Accessed: March 26, 2018)

Bies, D.A., Hansen, C.H., 1988b. Engineering Noise Control: Theory and Practice. Taylor & Francis, Abingdon, UK. <https://doi.org/10.4324/9780203163900> (Accessed: March 26, 2018)

Cao, L., Fu, Q., Si, Y., Ding, B., Yu, J., 2018. Porous materials for sound absorption. Composites Communications 10, 25–35. <https://doi.org/10.1016/j.coco.2018.05.001> (Accessed: April 10, 2018)

Dedigama, K.N.H., Shyaman, S.M.P., 2013. Investigation of natural material to reduce industrial noise. ICSBE-2012 Int. Conf. Sustain. Built Environment.

Ersoy, Sezgin, and Haluk Küçük. (2009). "Investigation of Industrial Tea-Leaf-Fibre Waste Material for Its Sound Absorption Properties." *Applied Acoustics* 70 (1): 215–20. <https://doi.org/10.1016/j.apacoust.2007.12.005>. (Accessed: June 15, 2018)

Gheorghe, A., 2013. Increasing Noise Reduction Level through Association of Soundproofing and Soundization Materials at Realisation of Modular Structural Elements of Acoustic Protection. http://imsar.bu.edu.ro/SISOM_Papers_2013/A11.pdf (Accessed: May 20, 2018)

Great Britain Environment Agency, (GBEA) 2001. Guidance on noise reduction at permitted processes. Environment Agency, Bristol.

Hansen, C.H., 2001. Fundamentals of acoustics. World Health Organization https://www.sepa.org.uk/media/156907/ppc_noise_guidance.pdf (Accessed: October 10, 2017)

Hosseini Fouladi, M., Nor, M.J.M., Ayub, M., Ghassem, M., 2012. Enhancement of coir fiber normal incidence sound absorption coefficient. *J. Comput. Acoust.* 20, 1250003. <http://www.worldscientific.com/doi/abs/10.1142/S0218396X11004493> (Accessed: June 16, 2018)

Jayamani, E., Hamdan, S., Suid, N.B., 2013. Experimental Determination of Sound Absorption Coefficients of Four Types of Malaysian Wood. *Appl. Mech. Mater.* 315, 577–581. <https://doi.org/10.4028/www.scientific.net/AMM.315.577> (Accessed: March 12, 2018)

Kim, K., 2015. Sources, Effects, and Control of Noise in Indoor/Outdoor Living Environments. *Journal of the Ergonomics Society of Korea* 34, 265-278. <https://doi.org/10.5143/JESK.2015.34.3.265> (Accessed: April 10, 2018)

Kuczmariski, M.A., Johnston, J.C., 2011. Acoustic Absorption in Porous Materials 27. <https://ntrs.nasa.gov/archive/nasa/casi.ntrs.nasa.gov/20110011143.pdf> (Accessed: July 15, 2018)

Liu, Zhengqing, Jiaying Zhan, Mohammad Fard, and John Laurence Davy. (2016). "Acoustic Properties of a Porous Polycarbonate Material Produced by

- Additive Manufacturing.” *Materials Letters* 181: 296–99. <https://doi.org/10.1016/j.matlet.2016.06.045>. (Accessed: July 10, 2018)
- Maderuelo-Sanz, Rubén, Juan Miguel Barrigón Morillas, Manuel Martín-Castizo, Valentín Gómez Escobar, and Guillermo Rey Gozalo. (2013). “Acoustical Performance of Porous Absorber Made from Recycled Rubber and Polyurethane Resin.” *Latin American Journal of Solids and Structures* 10 (3): 585–600. <https://doi.org/10.1590/S167978252013000300008>. (Accessed: July 15, 2018)
- Mitchell, s., 2001. Best Available Techniques for Control of Noise & Vibration (Technical Report). Environment Agency, Bristol.
- Murthy, V.K., Majumder, A.K., Khanal, S.N., Subedi, D.P., 2007. Assessment of traffic Noise Pollution in Banepa, A semi urban town of Nepal. Kathmandu University Journal of Science, Engineering and Technology. 3, 12–20.
- Oyedepo, O.S., Saadu, A.A., 2010. Evaluation and analysis of noise levels in Ilorin metropolis, Nigeria Environmental Monitoring and Assessment 160, 563-577. <https://doi.org/10.1007/s10661-008-0719-2> (Accessed: March 10, 2018)
- Rwawiire, Samson, Blanka Tomkova, Jiri Militky, Lubos Hes, and Band Madhukar Kale. (2017). “Acoustic and Thermal Properties of a Cellulose Nonwoven Natural Fabric (Barkcloth).” *Applied Acoustics* 116: 177–83. <https://doi.org/10.1016/j.apa.coust.2016.09.027>. (Accessed: July 15, 2018)
- Roit, S., 2009. Acoustic materials. https://svetlanaroit.files.wordpress.com/2009/11/about_material1.pdf (Accessed: June 20, 2018)
- Rozli, Z., Zulkarnain, Z., and others, 2010. Noise control using coconut coir fiber sound absorber with porous layer backing and perforated panel. *American Journal of Applied Sciences* 7, 260–264.
- Safe Work Australia, (SWA) 2011. Managing noise and preventing hearing loss at

work: Code of Practice. Safe Work Australia, Sydney.

Tang, X. and Yan, X., 2017. Acoustic energy absorption properties of fibrous materials: A review.

Composites Part A: Applied Science and

Manufacturing 101, 360-380. [https://doi.org/10.1016/j.compositesa.2017.](https://doi.org/10.1016/j.compositesa.2017.07.002)

07.002 (Accessed: June 26, 2018)

Tsaloglidou, A., Koukourikos, K., Pantelidou, P., Katsimbeli, A., Monios, A.,

Kourkouta, L., 2015. Noise Pollution as a Cardiovascular Health Hazard.

Int. J. Eng. Appl. Sci. IJEAS 2, 82–85.

Utilization of sawdust and coconut coir fibre as noise reducing wall surface materials.

Civ. Eng. Res. Exch. Symp. 16-19. <http://dl.lib.mrt.ac.lk/handle/123/8928> (Accessed:

May 25, 2018)

U-Dominic, C.M., Ezeabasili, A.C.C., Okoro, B.U., 2014. Industrial Noise Exposure

and Its Effects on Blood Pressure in Adult Industry Workers 5. [https://www.](https://www.longdom.org/articles/industrial-noise-exposure-and-its-effects-on-blood-pressure-in-adult-industry-workers.pdf)

[longdom.org/ articles/industrial-noise-exposure-and-its-effects - onblood-](https://www.longdom.org/articles/industrial-noise-exposure-and-its-effects-on-blood-pressure-in-adult-industry-workers.pdf)

[pressure-in-adult-industry-workers.pdf](https://www.longdom.org/articles/industrial-noise-exposure-and-its-effects-on-blood-pressure-in-adult-industry-workers.pdf) (Accessed: June 11, 2018)

Watson, F.R., 1927. Absorption of sound by materials: a method of measurement,

with results for some materials. University of Illinois at Urbana Champaign,

College of Engineering. Engineering Experiment Station., Urbana.

Xu, Xinwu, Huixiang Wang, Yan Sun, Jingquan Han, and Runzhou Huang. (2018).

“Sound Absorbing Properties of Perforated Composite Panels of Recycled

Rubber, Fiberboard Sawdust, and High Density Polyethylene.” *Journal of*

Cleaner Production 187 : 215–21. [https://doi.org/10.1016/j.jclepro .2018.](https://doi.org/10.1016/j.jclepro.2018.03.174)

03. 174. (Accessed: July 10, 2018)

KNUST

APPENDIX

Engineering drawings of the impedance tube and its accessories

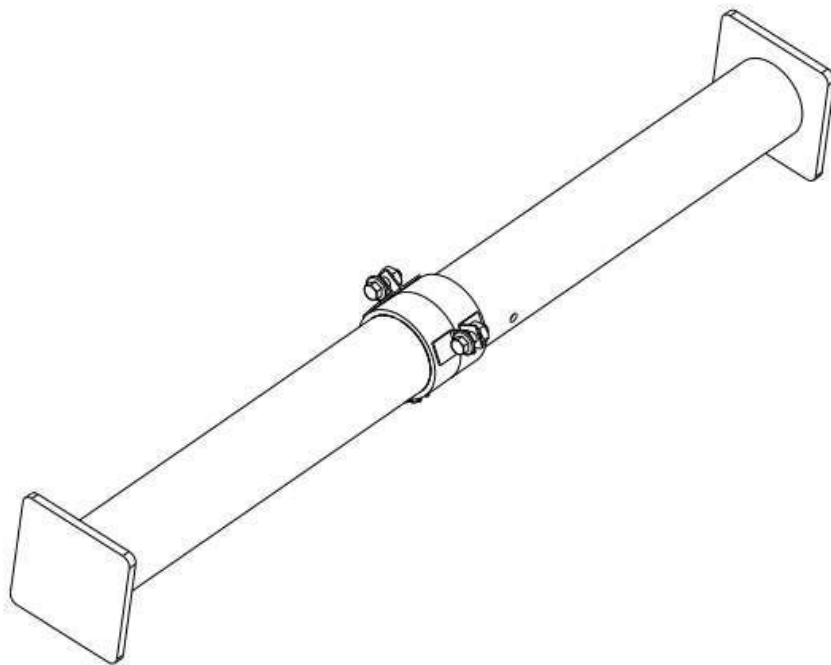

KNUST (Dept. of Mech. Eng)			
Title			
Impedance Tube			
SIZE	CAGE CODE	DWG NO	REV
C	001	001	1
SCALE: 1:1		UNIT: mm, 21 kg	SHEET 1 OF 9

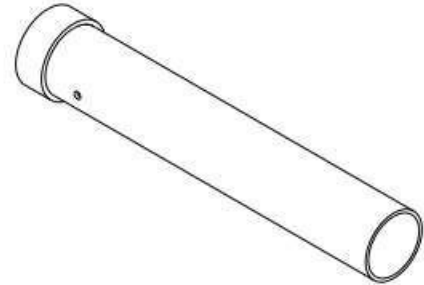
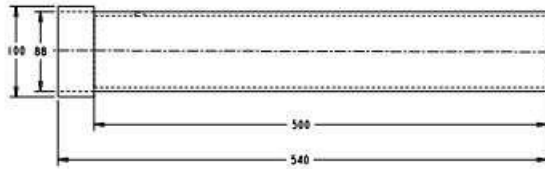
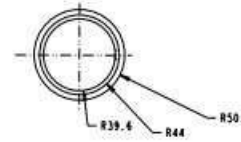

KNUST (Dept. of Mech. Eng)			
TITLE			
Impedance tube casing			
SIZE	CAGE CODE	DWG NO	REV
C	001	006	1
SCALE: 0.45		UNIT: mm, 21 kg	SHEET 6 OF 9

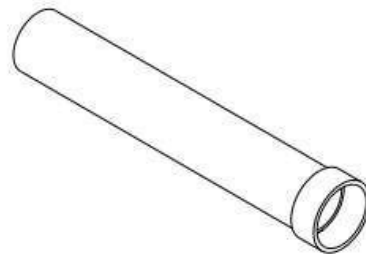
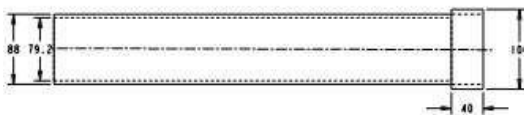
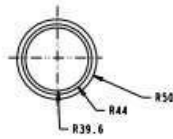

KNUST (Dept. of Mech. Eng)			
TITLE			
Impedance tube casing			
SIZE	CAGE CODE	DWG NO	REV
C	001	005	1
SCALE: 0.4		UNIT: mm, 21 kg	SHEET 5 OF 9

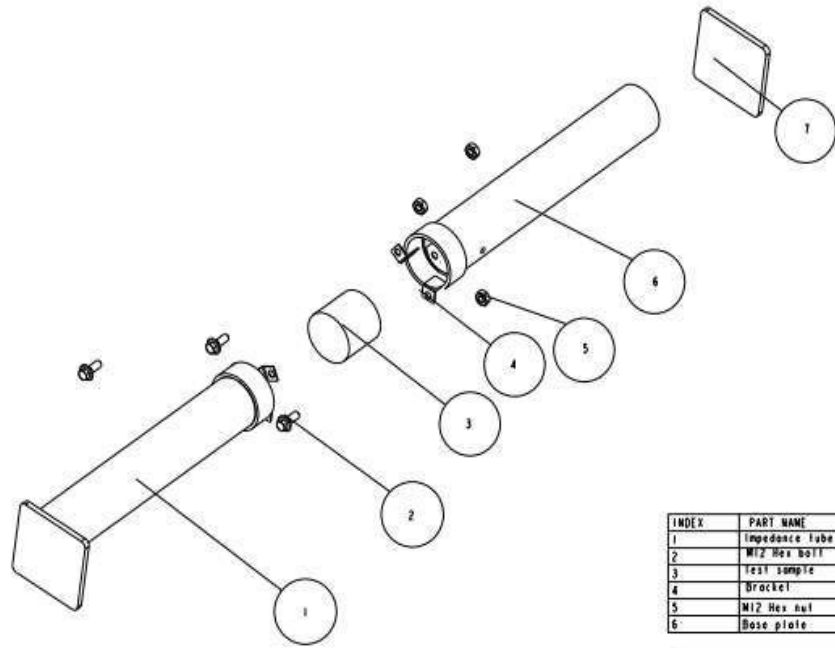

INDEX	PART NAME	REF. NUMBER
1	Impedance tube casing	166
2	M12 Hex bolt	2
3	Test sample	3
4	Bracket	4
5	M12 Hex nut	5
6	Base plate	7

KNUST (Dept. of Mech. Eng)			
TITLE			
Impedance Tube			
SIZE	CAGE CODE	DRG NO	REV
C	001	003	1
SCALE: 0.063		UNIT: mm, 23 kg	SHEET 3 OF 9

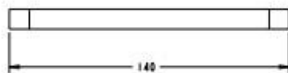
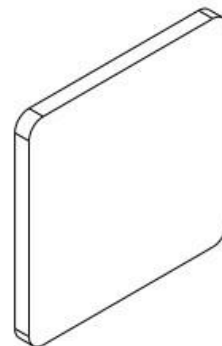
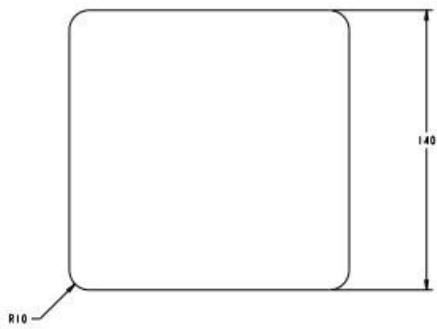

KNUST (Dept. of Mech. Eng)			
TITLE			
Impedance tube base plate			
SIZE	CAGE CODE	DRG NO	REV
C	001	007	1
SCALE: 1.000		UNIT: mm, 23 kg	SHEET 7 OF 9

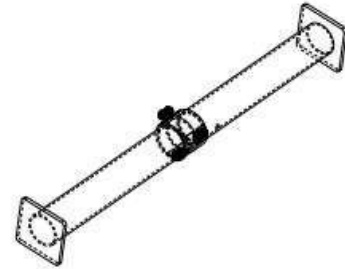
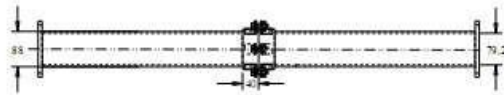
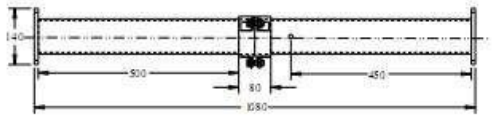

KNUST (Dept. of Mech. Eng)

11/14

Impedance Tube

SIZE	CAGE CODE	DWG NO	REV
C	001	004	1

SCALE: 1:1 UNIT: mm, 23 kg SHEET 4 OF 9

SCHEMATIC DIAGRAM OF THE EXPERIMENTAL SETUP

ITEM NO.	PART NUMBER	QTY.
1	Bolt	3
2	Impedance Tube	1
3	Test Sample	3
4	Nut	3
5	Support	2
6	Sound Level Meter	1
7	Laptop	1
8	Signal Generator	1
9	Sound Speaker	1
10	Cable	2

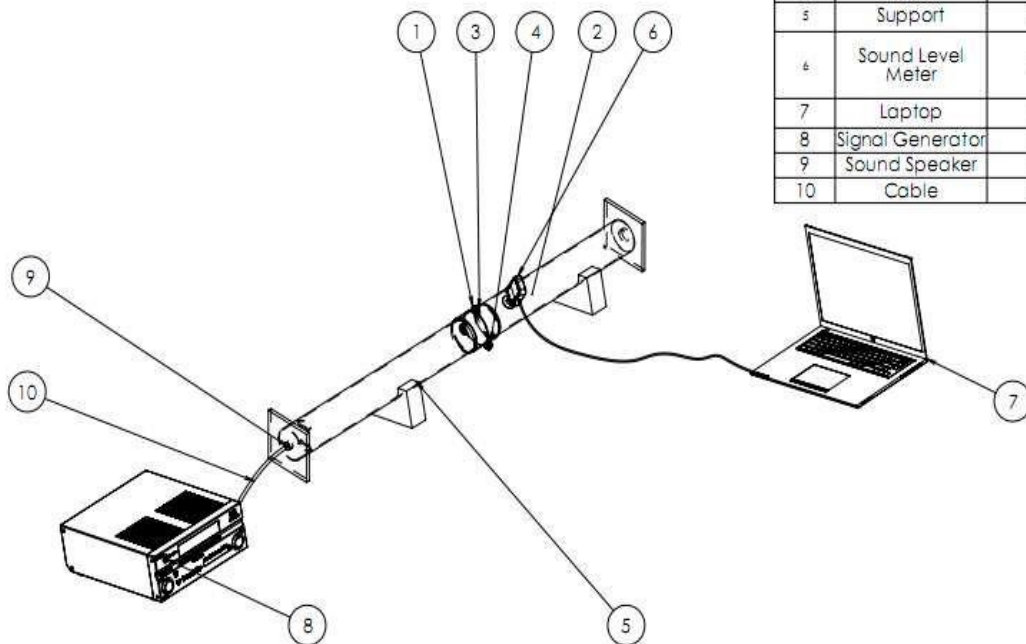

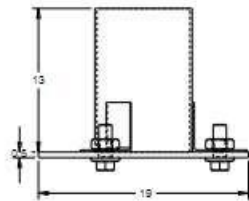
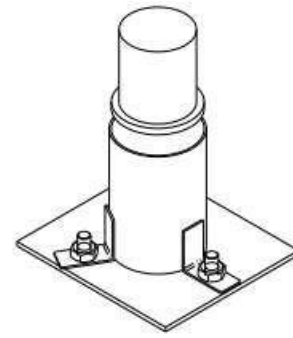
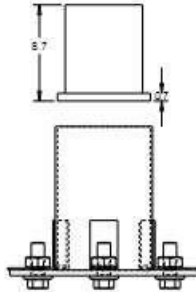
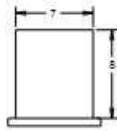
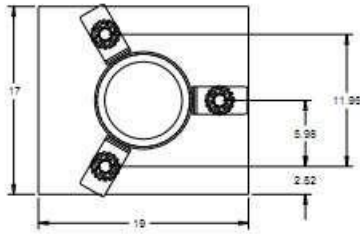

Hex Bolts & Nuts: M12 at 120° to each other

KNUST (Dept. of Mech. Eng)			
TITLE			
Mould			
SIZE	CAD CODE	ISSUE NO	REV
C	002	002	2
DRAWN BY		DATE	SHEET 2 OF 6

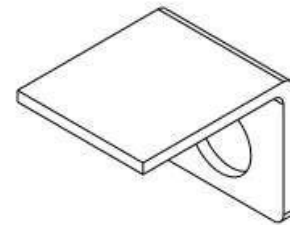
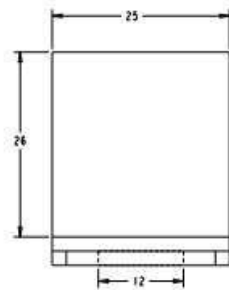
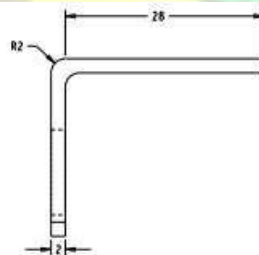
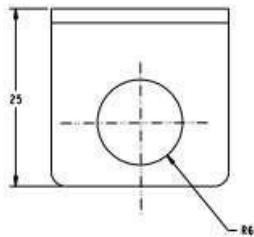

KNUST (Dept. of Mech. Eng)			
TITLE			
Impedance tube bracket			
SIZE	CAD CODE	ISSUE NO	REV
C	001	008	1
SCALE: 1:1		DATE: 04.02.21	SHEET 8 OF 9

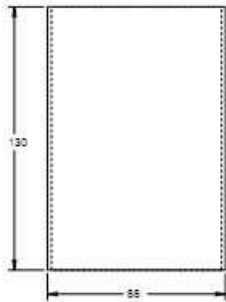
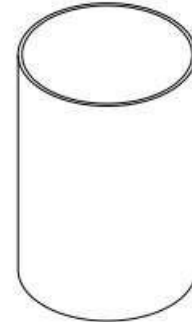
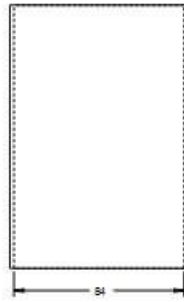

KNUST (Dept. of Mech. Eng)			
TITLE Cylinder			
SIZE	DATE CODE	DRG NO	REV
C	003	003	1
SCALE: 1:1			SHEET 2 OF 2

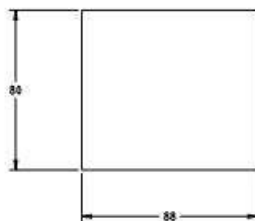
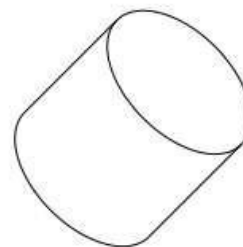
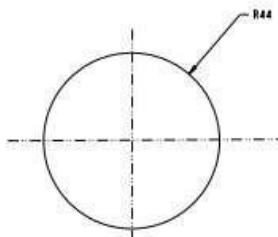

KNUST (Dept. of Mech. Eng)			
TITLE Test sample			
SIZE	DATE CODE	DRG NO	REV
C	001	001	1
SCALE: 1:100			SHEET 3 OF 3